

GEORGE
BARNSDALE

Est. 1884 —————

Owners'
Manual

TIMBER WINDOWS & DOORS

Your Windows & Doors

Thank you for choosing George Barnsdale timber windows and doors.

Our products are designed to provide you with years of high performance with minimal maintenance. This commitment to performance and longevity is backed by industry-leading guarantees which are reinforced by our suppliers.

To maximise the appearance and performance of your new windows and doors it's essential that they are operated and maintained properly in accordance with the instructions contained within this **Owners' Manual**. By following this step-by-step guidance you'll also ensure that your guarantees remain valid.

Contents

Maintenance Summary

- 4 Guarantee Registration
- 5 Maintenance Checklist
- 6-8 Coating Maintenance
 - Cleaning your window and doors
 - Applying the Window and Door Care Set
 - Recoating
 - Repairing damage to the coating
- 9 Hardware Maintenance
 - Weather seals
 - Furniture

Product Specific Operation & Maintenance

- 10-11 Casement Windows
- 11-12 Sliding Sash Windows
- 13-14 Tilt & Turn Windows
- 15 Pivot Windows
- 16-18 Entrance & French Doors
- 19 Tilt & Sliding Doors
- 20 Sliding Doors
- 21 Bifolding Doors (Outward Opening)
- 22 Bifolding Doors (Inward Opening)

Guarantee Registration

The first step to take once your new windows and doors have been installed is to register your guarantees with us. To register, simply return the *Window and Doorset Guarantee Registration Form*, with all of the relevant information completed, within 28 days of delivery.

Our commitment to performance and longevity is backed-up by industry-leading guarantees. Whilst we offer standard guarantees, sometimes the location of the property and the positioning of the products will impact the length of the guarantee term. This is summarised in **Our Guarantees** brochure which is available to download from our website.

As standard, we offer the following guarantees:



Paint Finish
Manufacturer's guarantee against paint coating system failure.



Stain Finish
Manufacturer's guarantee against stain coating system failure.



Preservative
Manufacturer's guarantee against preservative failure.



Glazing Unit
All drained and vented units have a 10 year manufacturer backed guarantee.



Hardware
Manufacturer's guarantee for all window and door hardware.



Weather Seals
Manufacturer's guarantee against failure of weather seals.

Please be aware that your guarantees will only remain valid if the instructions within this **Owners' Manual** have been followed. If you have any issues with your products, whether within the guarantee period or afterwards, call us on **01775 823000** or email us on customer@georgebarnsdale.co.uk providing detailed information and any pictures that will help to clarify the issue.

For further details on all guarantees, including exclusions, please visit the Guarantees section of our website www.georgebarnsdale.co.uk.

Maintenance Checklist

The checklist below summarises the simple maintenance procedures that need to be followed. We are confident that by following these steps your products will last a lifetime with very little effort.

To be carried out on a quarterly basis:

- The cleaning of your windows and doors, including furniture (see the *Cleaning your windows and doors* section on page 6 and the *Furniture* section on page 9 for further details).
- Cleaning of the weather seals to remove any dirt or debris (see the *Weather seals* section on page 9 for further details).

To be carried out on an annual basis:

- Lubricate all moving parts, including furniture, with an acid free oil or grease (see the *Furniture* section on page 9, plus the relevant product operation and maintenance page for further details).
- For coatings applied to European Oak timber and for light oak stains on other timbers, an annual application of the **Window and Door Care Set** is required in order to maintain the guarantee (See applying the window and door Care Set on page 6 for further details).

For all other coatings, we recommend an application of the Care Set 5 years after installation to prolong the life of the coating beyond the guarantee. (Details on page 6)

To be carried out as required:

- When the opening of the window or door becomes more resistant to movement than normal, then lubricate as required with an acid free oil or grease (see the relevant operation and maintenance product page for further details).

Coating Maintenance

Our focus is to achieve long life with low maintenance. We are able to provide a standard ten year guarantee on paint finishes because of the premium materials that we use and the way in which we apply the coating. In reality, we are confident that the coating will last much longer, as long as some simple maintenance is carried out.

For ease of use, the maintenance guidance is summarised below in the format of questions and answers. Please note, all of the guidance below relates to the window frames and sashes.

Cleaning your windows and doors

Q: How often should I clean my windows and doors?

A: This should be done at least quarterly, usually at the same time as cleaning the glass. Cleaning on a quarterly basis will help to prevent any fungal build-up and provide an opportunity to inspect for any damage or coating wear.

Q: Which detergent should I use to clean my windows and doors?

A: Wash with hot soapy water (any mild liquid detergent solution will suffice) to remove any contaminants, frequently changing the water. After washing, rinse thoroughly with clean water to remove all residue, then wipe dry with a clean cloth.

Q: What should I do in the case of stubborn dirt?

A: For stubborn dirt it may be necessary to use a stronger, non-abrasive cleaner such as bathroom cleaner. Apply with a non-abrasive scouring pad, then rinse thoroughly with clean water to remove all residue. Wipe dry with a clean cloth.

Q: What should I do if I find signs of fungal growth?

A: If any fungal growth is found, apply a solution of one part household bleach to two parts water. Leave the solution for approximately twenty minutes to act, then rinse thoroughly with clean water to remove all residue. Wipe dry with a clean cloth.

Applying the Window and Door Care Set

Q: What is the Window and Door Care Set?

A: Supplied free of charge with all products made from European oak timber and for light oak stains on other timbers, the Window and Door Care Set is designed to significantly extend the life of the coating beyond the guarantee period. For all other products, when required, the Care Sets can be obtained by contacting us on **01775 823000** or email customercare@georgebarnsdale.co.uk.

Q: How often should I apply the Care Set?

A: For products made from European Oak timber and all timbers stained with light/natural oak, it is a requirement of the guarantee to apply an application of the Care Set annually. For all other products we recommend a first application of the Care Set between 4-5 years after purchase. Kits can be purchased directly from us (see details on previous page).

Q: How should I apply the Care Set?

A: This is a simple two-step process which is summarised below:

Step 1 - Clean the surface of the windows and doors as per the instructions detailed in the section *Cleaning your windows and doors*. Apply the Care Set's cleaning fluid with a damp cloth, following the instructions supplied on the bottle.

Step 2 - Following the instructions on the bottle, apply the balsam with the cloth included covering the frame of the window/door and any exposed edges.

Recoating

Q: When do I need to recoat?

A: Recoating is only necessary when the coating begins to show signs of wear, such as colour fading and significant loss of sheen, or after the repair of damage.

Q: How do I order the paint or stain to recoat?

A: We supply the full range of products which are required to recoat your windows and doors. If you wish to place an order please call us on **01775 823000** or email customercare@georgebarnsdale.co.uk.

Q: How do I know which colour paint or stain to order for recoating?

A: We will have a record of your original order, so will be able to let you know what you need to order based on the original specification.

Q: What is the recommended process that I need to follow when the time comes to recoat?

A: Recoating a paint or stain finish is extremely simple providing the following steps are taken:

Step 1 - Clean the window or door as per the instructions detailed in the section *Cleaning your windows and doors*. Rinse thoroughly to remove all residue then wipe with a damp cloth and allow to dry.

Step 2 - If the surface is looking weathered then it can be recoated without preparative sanding. If there is any sheen to the coating then before applying the relevant paint or stain, it's recommended to lightly sand with a fine abrasive, such as p240 or finer. After sanding, wipe with a very lightly dampened sponge to remove sanding dust and then wipe dry with a clean cloth.

Step 3 - Apply a brush application of an approved coating. For paint colours, you will need to apply two to three coats of **Remmers Compact Opaque PU**. For stains you will need to apply two to three coatings of **Remmers Compact Stain PU**. It's essential that a synthetic brush designed specifically for the application of water-borne coatings is used.

Repairing damage to the coating

Q: What signs of damage should I look out for?

A: The signs of wear and damage to look out for are:

- Flaking or cracking of the paint coating;
- A loss of colour or sheen in the paint finish;
- Exposed timber.

Q: What should I do if I notice damage?

A: If you do notice flaking or cracking of the paint, or identify exposed timber, the table below summarises the process for repairing damage. It's essential that a synthetic brush designed specifically for the application of water-borne coatings is used.

A step-by-step guide to repairing damage

	Required:	Procedure:
Step 1 – Preparation	For all repairs.	Any flaking or loose coating should be removed using an abrasive p150 grit sand paper. Ensure that the area is clean and free from dirt or grease prior to the application of coatings.
Step 2 – Sealing	If any end grains or open joints are exposed.	Seal the end grains using Remmers End Grain Sealer* . Fill any small cracks, cuts and open joints using the sealer.
Step 3 – Preservation, base staining	If the damage exposes bare timber.	Brush apply a coat of Remmers HK Stain Aqua* (in the appropriate colour if you are repairing a stain finish).
Step 4 – Priming opaque finishes	After any preservation of bare areas.	Brush apply Remmers Sealing Primer* .
Step 5 – Mid and finishing coats	To finish any repairs.	For intermediate and finishing coats on soft and hardwoods, apply two to three coats of Remmers Compact Opaque PU* for paint colours or Remmers Compact Stain PU* for stain colours.

*All consumable products (Care Set, paint, stains, etc.) can be ordered by calling us on **01775 823000** or emailing customercare@georgebarnsdale.co.uk.

Please note, approved products must be used to recoat your windows and doors. The use of unapproved products will invalidate the guarantee.

Hardware Maintenance

As well as allowing sashes and doors to operate correctly, the hardware plays a vital role in keeping everything square and preventing unwanted timber movement. As a result, maintenance is crucial to provide effortless smooth operation, ensuring the products provide long life with low maintenance. This section provides general maintenance guidance on hardware. In the following operation and maintenance pages of this manual (from page 10 onwards), there is detailed information on each window and door system which outlines all specific hardware set-up, operation and maintenance guidelines.

Weather seals

To ensure that the weather seals function correctly and to maximise their life, it's important to keep them free of any dirt or debris. We recommend that you check the seals at the quarterly maintenance check and if you find any dirt or debris, remove them using warm water with a mild detergent. For products that are opened regularly, it's recommended to check more frequently.

Furniture

The fitted furniture should be cleaned when the windows and doors are cleaned, which we recommend be carried out on a quarterly basis. The cleaning process varies by which Furniture Collection you have chosen, and is summarised below:

Furniture Collection	Guidance on handle cleaning
The Original Collection The Classic Collection The Patio Collection The Modern Collection The Sash Collection Applicable to the following finishing options: gold, polished chrome, satin chrome, white, black.	Wipe clean with a damp cloth. If required, soak the cloth in warm soapy water (any mild liquid detergent will do), then squeeze out excess water before application. After cleaning, wipe dry with a clean cloth.
The Classic Collection Applicable to the polished brass finishing option only.	The polished brass option is supplied unlaquered on all external furniture for a more durable finish. The unlaquered finish can either be left to take on an antique brass finish or cleaned using a quality metal cleaner to maintain the polished finish.
The Foundry Collection Applicable to the following finishing options: black, pewter.	These are traditional painted iron handles and therefore require regular maintenance. Wipe clean using a lightly oiled cloth. Apply a light clear grease to the contact area between the handle and face plate and between the screws and the face plate.

We recommend that all moving parts on all handles are lightly oiled at least once a year to allow the action to remain smooth and protect any uncoated surfaces.

Please note, for particularly harsh and corrosive environments, such as coastal locations and those areas exposed to high levels of industrial and agriculture pollution, more regular maintenance will be required.

Casement Windows

(C1/C2/C3/C4)

Operation

The window is opened by turning the handle to 90° and then pushing the sash open. Dependant on the hinge type the sash will then open until it reaches its limiter. This varies as follows:

Standard egress and easy clean hinge

Egress

Under normal operation the window will open fully to 90° allowing the window to be used as an escape route in an emergency.

Easy clean

Open the window 20° to reveal the two purple restrictors in the track of the hinge, push and slide the restrictors down the track until they reach the next locking position. Continue to push the window open, the hinge side of the window should start to slide away from the frame for the easy clean purpose. To reset the hinge fully close and reopen the window.

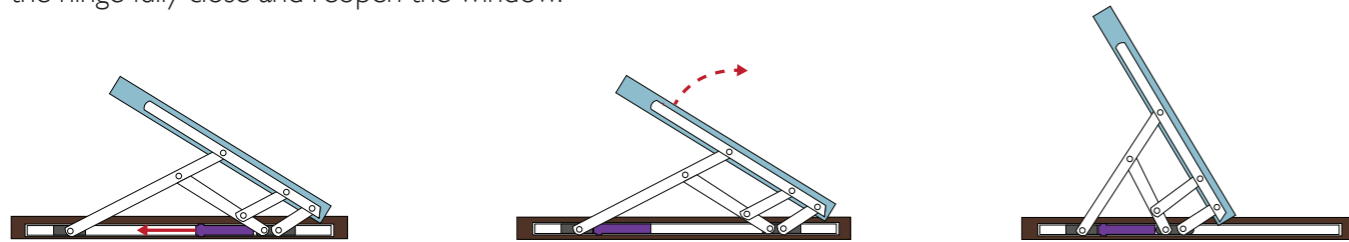

Figure 01: Operation of egress and easy clean hinges

Restrictor and easy clean hinge

Unrestricted opening

Under normal operation the window will open to 15-20° at which point the restrictor will stop the window from opening further. To clear the restrictor open the window until it stops at this point, push the green button on the top hinge and push the window open slightly, then push the green button on the bottom hinge and the window will open unrestricted to its fully open state. To reset simply close the window.

Easy clean

Repeat the above process to fully open the window. As before press the green button on the top hinge and apply some pressure to the sash pushing towards the centre of the frame. Repeat this for the green button on the bottom hinge and the sash will slide towards the middle of the frame. To reset the window reverse the process and close the window.

Night vent position



Figure 02: Operation of restrictor and easy clean hinges

The window may be provided with a night vent keep which allows the sash to be opened slightly and locked in position to provide ventilation and security. This function is provided by a dual keep.

Maintenance

Dual Keep: A dual keep has a secondary locking position, which can be utilised by opening the window as normal by approximately 10mm and then returning the handle to the closed position ensuring that the locking system engages in the second position.

Lubrication

All moving parts should be lubricated, using acid free oil or grease whenever the mechanism becomes dry, which is evident when any operation becomes more resistant to movement than normal. To ensure that you get the maximum life out of your windows and hardware we recommend that all moving parts are lubricated once a year.

Sliding Sash Windows

(S1/S2/S3)

Operation

Sliding

The fastener on the top of the sash meeting rail can be opened by unscrewing the locking screw and pushing the thumb pad allowing the catch to rotate free of the keep. Once done the sashes are free to slide up and down, usually by lifting up the bottom sash pulls or pulling down on the top sash eye or D handle. The movement may be restricted by the sash stops.

Sash stops

Sash stops allow the sash to be opened to a fixed position to provide ventilation and security. The stops are activated by either a manual push and twist mechanism or a locking version using a supplied key. The stops are activated when the pin is protruding out of the body and inactive when retained inside the body.

Tilt mechanism

The tilting mechanism, if fitted, is operated by sliding the two release catches on the bottom sash meeting rail towards the centre of the sash. Whilst holding the catches pull the sash towards you and down. To tilt the top sash, lower the sash to reveal the catches then repeat the process. To close, push the top sash back into the frame making sure the release catches click back into their original position, then repeat for the bottom sash.

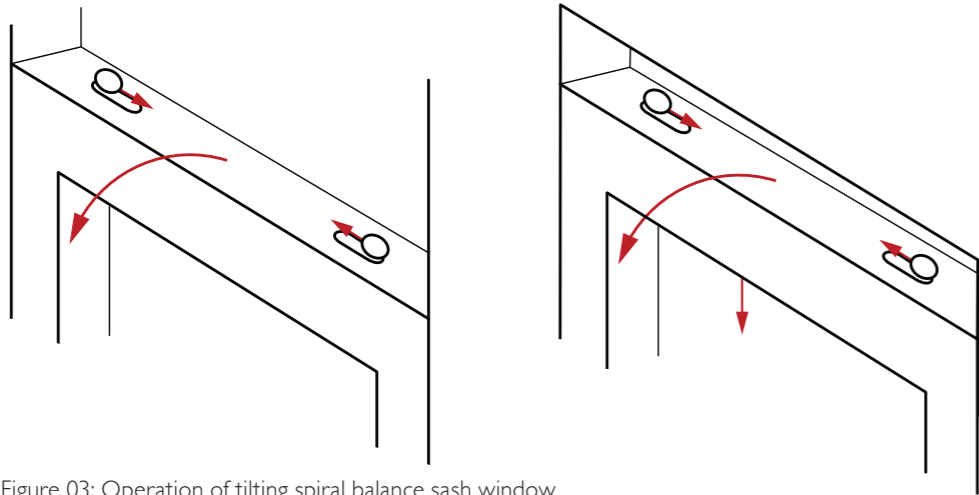

Figure 03: Operation of tilting spiral balance sash window

Maintenance

Lubricating balances

Depending upon location, cleaning and lubrication of the balance may be desirable after a length of time, the period of which will depend on the window location and the frequency of use. A few drops of light oil applied via the top end of the tube will always improve the operation of the balance and extend its life.

Adjusting balances

Try the sashes up and down to the limit of their travel. If there is a tendency for either sash to drop when in the up position, adjust the balance as follows (see Figure 04):

- Insert a screwdriver into the slot in the ratchet fitting at the bottom of the balance.
- Adjust by turning the ratchet in an anti-clockwise direction as viewed from underside. Please note, two clicks of the ratchet is equal to one complete turn.

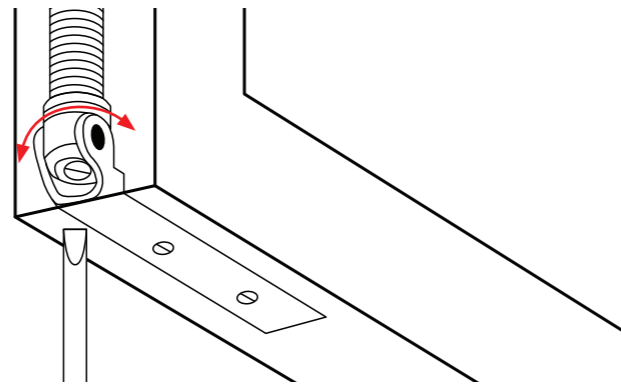

Figure 04: Adjusting a spiral balance sash window

IMPORTANT: Do not over tension.

Tilt & Turn Windows (EI)

Operation

The handle can be set to 90° to tilt and 180° to open fully.

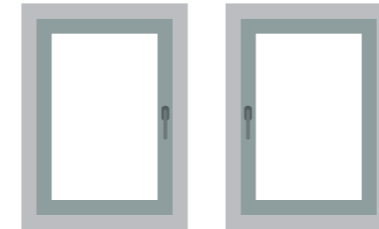

Figure 05: Handle down - closed

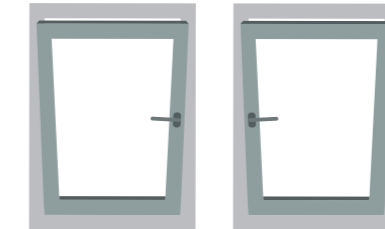

Figure 06: Handle 90° - Open Tilt*

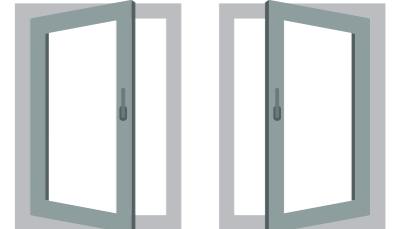

Figure 07: Handle 180° - Open Turn*

*If you have a tilt only or turn only window you only have to rotate the handle through 90°

IMPORTANT: The window must be closed before switching the opening (tilt/turn) mode.

Maintenance

Lubrication

All moving parts should be lubricated, using acid free oil or grease, whenever the mechanism becomes dry which is evident when any operation becomes more resistant to movement than normal. To ensure that you get the maximum life out of your windows and hardware we recommend that all moving parts are lubricated once a year. The following diagrams highlight the moving parts which will need attention:

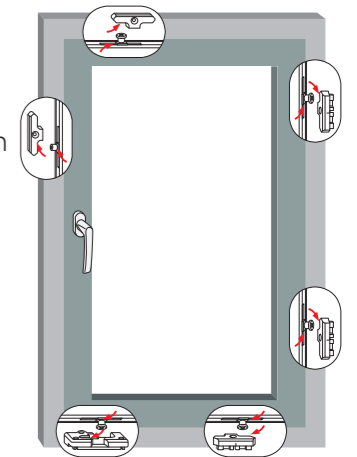

Figure 08: Locking oiling locations

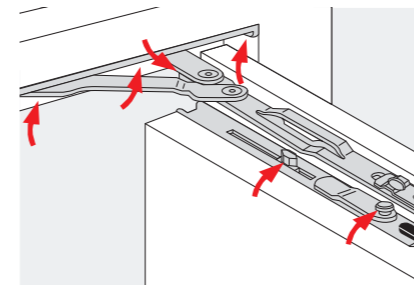

Figure 09: Top hinge oiling locations

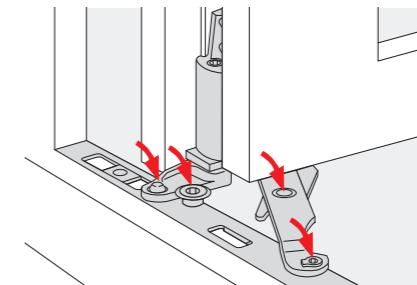

Figure 10: Bottom hinge oiling locations

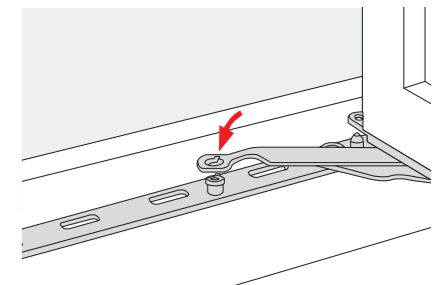

Figure 11: Bottom hinge oiling locations

Adjustments

The sash can be adjusted in multiple ways to ensure that it opens smoothly and closes tightly; adjustments can be made to the sash stays and corner hinges as shown in the diagrams below:

Sash stay adjustments

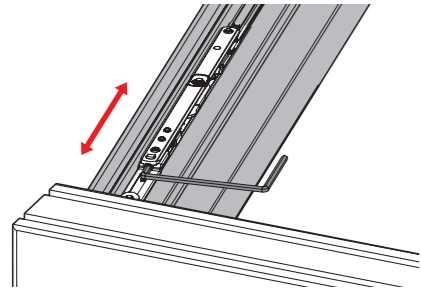

Figure 12: Horizontal adjustment $\pm 2.0\text{mm}$

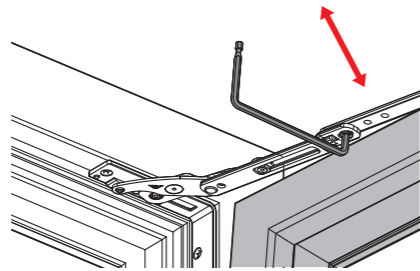

Figure 13: Compression adjustment $\pm 0.5\text{mm}$

Pivot hinge adjustments

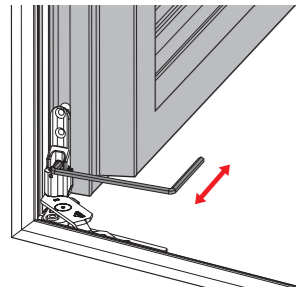

Figure 14: Horizontal adjustment $+2.0/-1.5\text{mm}$

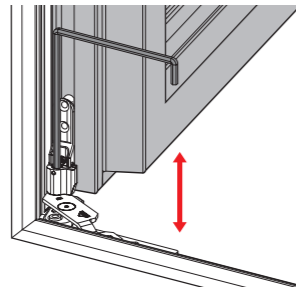

Figure 15: Height adjustment $+1.5/-1.0\text{mm}$

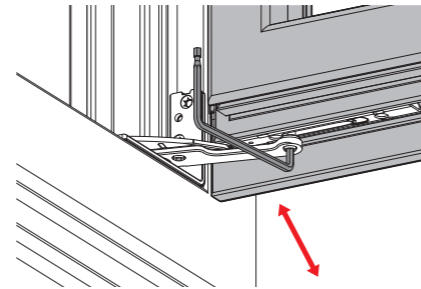

Figure 16: Compression adjustment $\pm 0.5\text{mm}$

Pivot Windows (PI)

Operation

The sash is opened by turning the handle 90° and pushing outwards. The pivot friction hinge allows the sash to be opened by the right amount and then held in position. In order to clean the window, the sash can be rotated by 180° , so the outside glass is now on the inside. To do this, open the sash as normal allowing the top of the sash to lower down. Once in reach, the top of the sash can then be pulled to give a full rotation.

In cases where a restrictor is fitted the initial opening will hit a stop after 10° to 20° of movement. In this case the restrictor can be released by rotating the locking cam with the use of a 4mm Allen Key (see Figure 18).

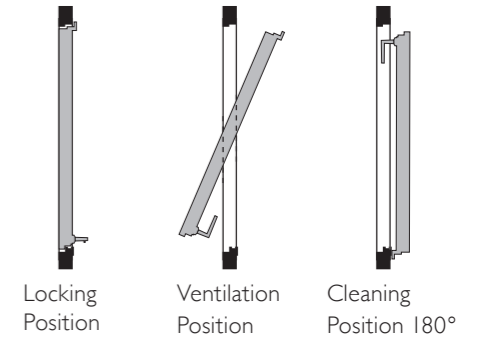

Figure 17: Pivot window positions

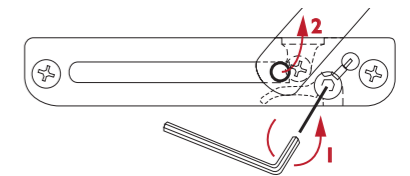

Figure 18: Removing window restrictor

Maintenance

Lubrication

All moving parts should be lubricated, using acid free oil or grease, whenever the mechanism becomes dry which is evident when any operation becomes more resistant to movement than normal. To ensure that you get the maximum life out of your windows and hardware we recommend that all moving parts are lubricated once a year.

Adjustment

Our pivot windows are fitted with either flush or surface hinges, depending on their size and shape. Both hinges can be adjusted to increase or decrease the friction, making the window harder or easier to open - as shown below:

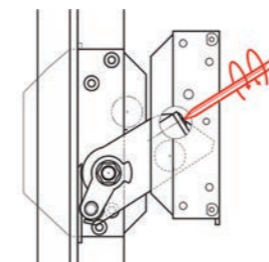

Figure 19: Flush hinge adjustments

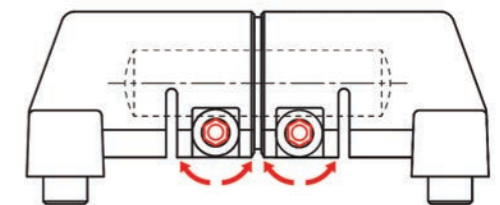

Figure 20: Surface hinge (SW4 fitting) adjustments

Entrance & French Doors

(DS2/DS3/DS5/DS6)

Our doorsets are usually supplied with at least three hinges and multi-point locking. Providing these are kept properly adjusted, and the door lock bolts are fully engaged, they will stop any movement of the door stiles. If the door is not evenly compressing the weather seals, this may cause permanent damage.

Operation

Different locking system options:

Standard lock

To open a standard door, first the door should be unlocked using the key in the locking cylinder. Once it is unlocked the door can be opened by turning the handle in a downwards direction. The locking system works by first engaging a latch when the door is closed. Then the handle should be lifted, which engages the hook bolts at the top and bottom of the door, providing extra security and further support to the door to ensure it fits squarely and flush in the frame. After engaging the hooks the door can then be locked using the key in the cylinder.

Auto-lock

To open an auto-lock, the door can be unlocked with a turn of the key and then the hooks can be disengaged with a further quarter turn of the key. If the door has not been locked, a quarter turn of the key will allow it to be opened. If there is a handle on the inside, the process of opening is the same as a standard door. To apply the dead bolt, turn the key one rotation as the hooks are engaged automatically.

Heritage lock

The door is operated by the key on the outside and a thumb turn on the inside. When the door closes the multi-point locking engages automatically.

CAUTION: Thumb Turn Euro Cylinder Operation

Please note, care should be taken when using a thumb turn cylinder. The thumb turn cylinder is spring loaded for security which is a safety feature whereby should the cylinder be attacked from the outside, it will prevent access to the lock mechanism.

In order to ensure that the lock is always in the correct position to prevent an external attack, it is essential that the thumb turn cylinder is pushed in to turn and must be released back to its original out position after every operation. If the thumb turn is left in the midway position, meaning that the spring mechanism has not been released, then you will encounter a problem whereby a key cannot be inserted fully from the outside.

On a lever/lever operation this means you could be locked out if a member of your household has locked the door from the inside and not returned the thumb turn to the correct position. On a lever/pad operation this means you could lock yourself out of your home if you do not return the thumb turn to the correct position on opening and the door closes behind you.

Stable lock

The top section of the door is operated in the same way as our standard lock with a handle each side. The lower half has a cylinder operated by key on the outside and thumb turn on the inside, which controls whether the two doors operate as one or only allowing the top door to open.

Maintenance

Lubrication

All moving parts should be lubricated, using acid free oil or grease whenever the mechanism becomes dry, which is evident when any operation becomes more resistant to movement than normal. To ensure that you get the maximum life out of your windows and hardware we recommend that all moving parts are lubricated once a year.

Keep adjustment

Most keeps we supply are fully adjustable. When the hinges have been adjusted, the keeps should also be adjusted.

Striker plate:



Should be adjusted to allow the door to latch shut but not so that it is necessary to slam it shut. Use a T15 torx to adjust the compression on the gasket by turning the eccentric cam located at the top and bottom of the adjustable striker plate.

Figure 21: Striker plate adjustment

Hook bolt plates:



Should be adjusted so that when the bolts are engaged it holds the stile true and against the seals. The seals will force the stile of the door away from them and it is important to stop the door warping to keep the stile true. Use a T15 torx to adjust the compression on the gasket by turning the eccentric cam located at the top and bottom of the adjustable hook bolt plate.

Figure 22: Hook bolt plate adjustment

IMPORTANT: Do not adjust with a power tool, hand tool adjustment only. These adjustments also need to be made at the installation stage.

Hinge adjustment

Most hinges we supply are fully adjustable. When the fitting is complete please check that the door is true and square in the frame with an equal gap. The standard hinges can be adjusted vertically and horizontally as shown in the series of diagrams on page 18.

IMPORTANT: To comply with the requirements of CE marked panic exit doors:

- Check that the door is correctly adjusted and lubricated at least once a month, and ensure that the force required to open is a maximum of 70N / 40Nm.

Flush door hinge (standard)

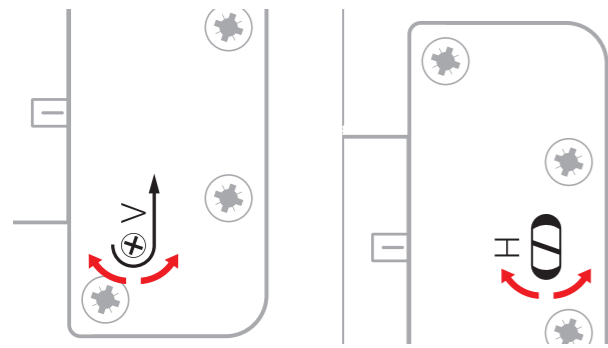

Figure 23: Vertical adjustment

Figure 24: Horizontal adjustment

All adjustments

The horizontal and the vertical adjustments are to be carried out without unhooking the door. Open the door by approximately 90° and adjust the sash vertically ($\pm 3\text{mm}$) by turning the "V" screw in the middle hinge. Adjust the sash horizontally ($\pm 2\text{mm}$) by turning the "H" screws in the upper and the lower hinge.

Concealed hinge

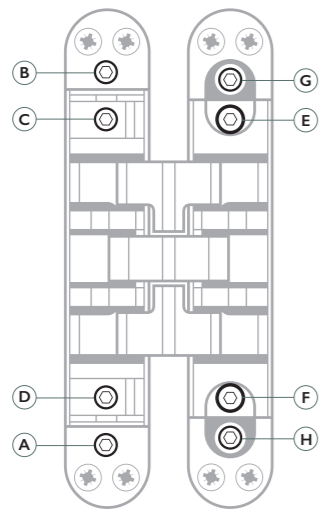

Figure 25: Concealed hinge adjustment locations

Horizontal adjustment

Tighten or loosen screws C and D to increase or decrease the air gap $\pm 3\text{mm}$.

Height adjustment

Loosen screw A by at least 3 turns, then tighten or loosen screw B to alter the height of the sash $\pm 3\text{mm}$. Lock by tightening screw A.

Compression adjustment

Loosen screws G and H. Tighten or loosen screws E and F to alter the compression $\pm 1\text{mm}$. Lock by tightening screws G and H.

Flush door hinge (stable door)

Unlock the hinge

The adjustment is to be carried out without unhooking the door. Open the door by approximately 90° and fix it by wedging. Loosen the two central clamping screws of each hinge.

Height & compression

Adjust the height ($\pm 3\text{mm}$) and the compression ($\pm 2\text{mm}$) of the door leaf by moving the sash in the appropriate directions.

Lock the hinge

Tighten the clamping screws and remove the wedges.

Horizontal adjustment

Adjust the horizontal position ($\pm 2\text{mm}$) by turning the upper and the lower screw of each hinge.

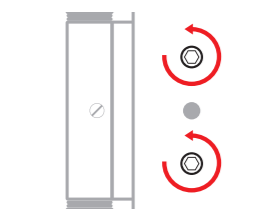

Figure 26: Unlocking the hinge

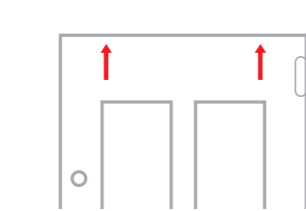

Figure 27: Height adjustment

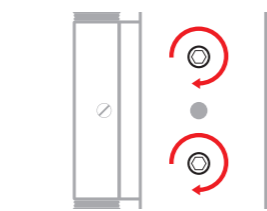

Figure 28: Locking the hinge

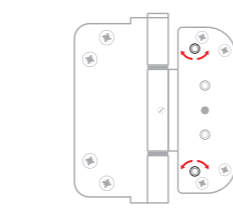

Figure 29: Horizontal adjustment

IMPORTANT: Do not adjust with a power tool, hand tool adjustment only.

Tilt & Sliding Doors (DS12)

Operation

The handle can be set to 90° to tilt open for secure ventilation and 180° to open fully.

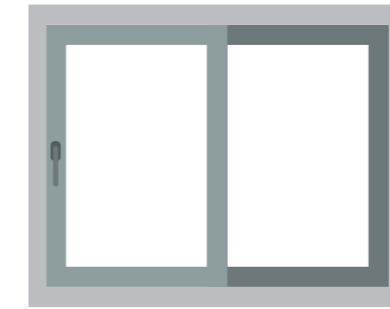

Figure 30: Handle down - locked

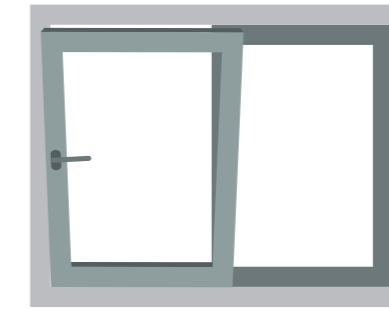

Figure 31: Handle at 90° - open tilt

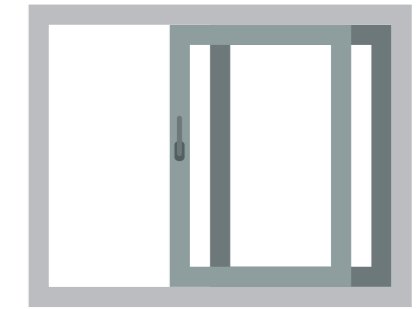

Figure 32: Handle at 180° - open slide

IMPORTANT: The doorset must be closed before switching to the open mode to avoid mishandling.

Maintenance

Lubrication

All moving parts should be lubricated, using acid free oil or grease whenever the mechanism becomes dry, which is evident when any operation becomes more resistant to movement than normal. To ensure that you get the maximum life out of your windows and hardware we recommend that all moving parts are lubricated once a year. Figure 33 highlights all moving parts.

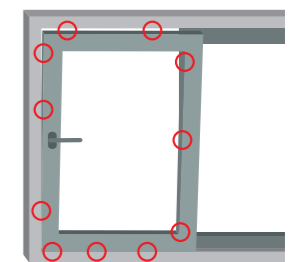

Figure 33: Moving parts

Adjustment

Test the parallel positioning in the sliding direction, and adjust if necessary. Loosen the clamping-screw for the connecting rod on the leading roller, align the sash parallel and tighten the clamping-screw firmly (as shown in Figure 34).

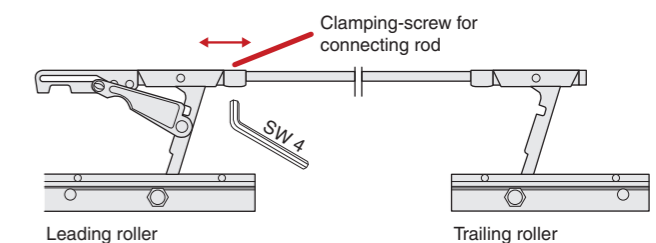

Figure 34: Adjust by loosening / tightening the clamping screw on the leading roller positioned on the bottom rail.

IMPORTANT: These adjustments also need to be made at the installation stage.

Sliding Doors

(DSI3)

Operation

The sliding doors can be locked by closing both doors fully and then moving the handle to point upwards. To set the night-vent, close both doors but allow a 10mm gap before locking the handle upwards. The sliding door can only be unlocked and move freely when the handle is pointing downwards.

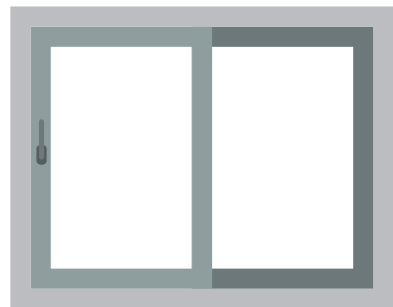

Figure 35: Handle up - locked

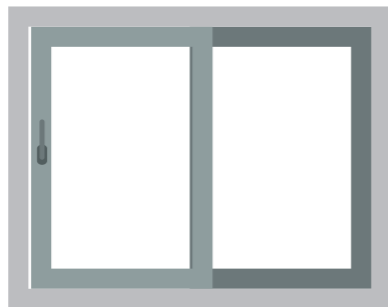

Figure 36: Handle up - locked but with 10mm gap (night-vent)



Figure 37: Handle down - unlocked

Maintenance

In order to ensure perfect permanent hardware operation, the following maintenance operations and/or inspections should be carried out:

- Free all hardware components from lime, cement and mortar splashes to prevent malfunctions due to obstruction. The (bottom) roller track must always be kept clean.
- Oil or grease all moveable parts and all locking points at least once a year. Use only acid-free oil or grease.

Bifold Doors

(Outward Opening DSI7)

Operation

To open the master door use the handle (and key if locked) to operate the multi-point lock (please refer to the **Entrance & French Doors** section on page 16 for more details on the locking systems). To open subsequent doors, the top and drop bolts should be retracted (this will require a key if they are the locking type) or if fitted, the intermediate handle should be rotated to retract the lock bolts. The doors are then free to slide on the track and can be held against the neighbouring door if the optional magnets have been fitted. Closing is the reverse of the opening process.

Maintenance

Lubrication

All moving parts should be lubricated, using acid free oil or grease, whenever the mechanism becomes dry which is evident when any operation becomes more resistant to movement than normal. To ensure that you get the maximum life out of your windows and hardware we recommend that all moving parts are lubricated once a year.

Adjustments

Vertical adjustment

1. With the doors closed, insert the shipping clip (as shown in Figure 38) into the hinge.
2. Adjust using a flat headed screwdriver.
3. Once the adjustment has been made, remove the shipping clip.

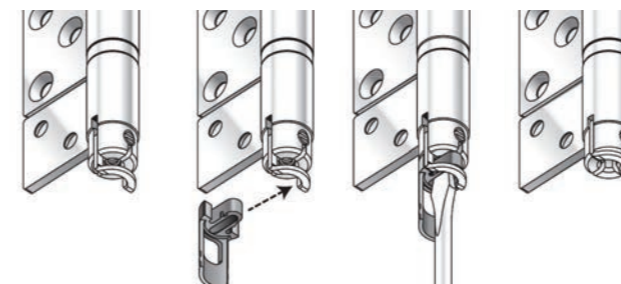

Figure 38: Vertical adjustment with shipping clip

Horizontal adjustment

1. With the doors open, using a flat headed screwdriver adjust the horizontal screws found in the top and bottom rollers (as shown in Figure 39).
2. Turning the screws clockwise will increase the gap between the frame and sash, turning anti-clockwise will reduce the gap.

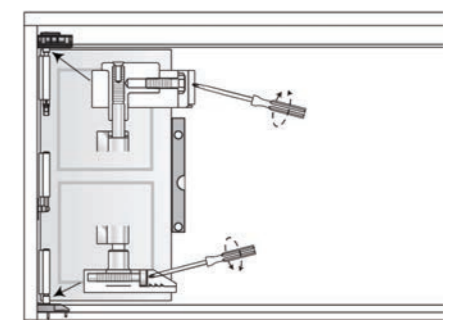

Figure 39: Horizontal adjustment roller locations

IMPORTANT: Ensure the shipping clip is kept safe for any future adjustments.

Bifold Doors

(Inward Opening DSI 6)

Operation

1. Open the master (first opening) door.
2. Open the slave (second opening) door until the top and bottom components engage each other.
3. Open the remaining doors and fold them together.
4. To close the doors, reverse the above process.

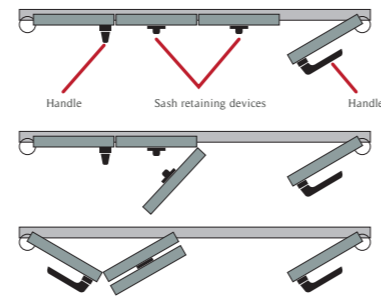

Figure 40: Opening of bifolding doors

Maintenance

Lubrication

All moving parts should be lubricated, using acid free oil or grease whenever the mechanism becomes dry, which is evident when any operation becomes more resistant to movement than normal. To ensure that you get the maximum life out of your windows and hardware we recommend that all moving parts are lubricated once a year.

Adjustments

Adjustment of the door spacing

1. Open the door to expose the hinge that requires adjusting.
2. Adjust the hinge by turning the centre head bolt using a 4mm Allen key.

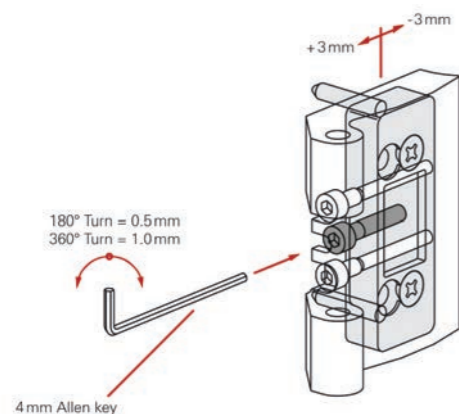

Figure 41: Door spacing adjustment

Adjustment of the sash via the roller

1. Remove the cover cap.
2. Loosen the lock-nut with a 17mm open-ended spanner.
3. Carry out the height adjustment by turning the threaded bolt using a 4mm Allen key.
4. Tighten the lock-nut again.
5. Replace the cover cap.

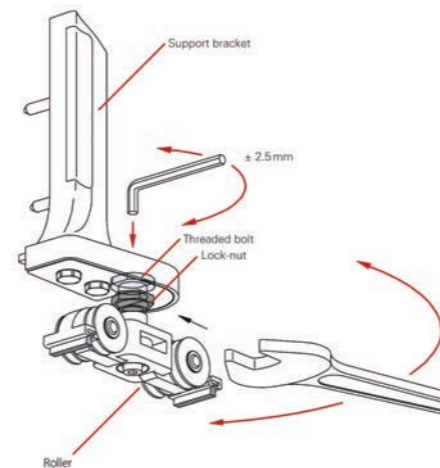

Figure 42: Adjusting the sash roller

