

ELEVATIONS

Outside View (Scale 1:15)

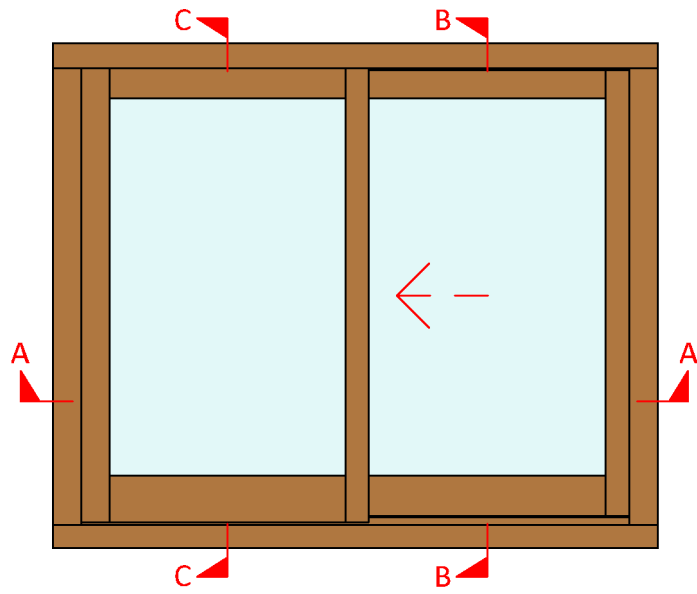

Inside View (Scale 1:15)

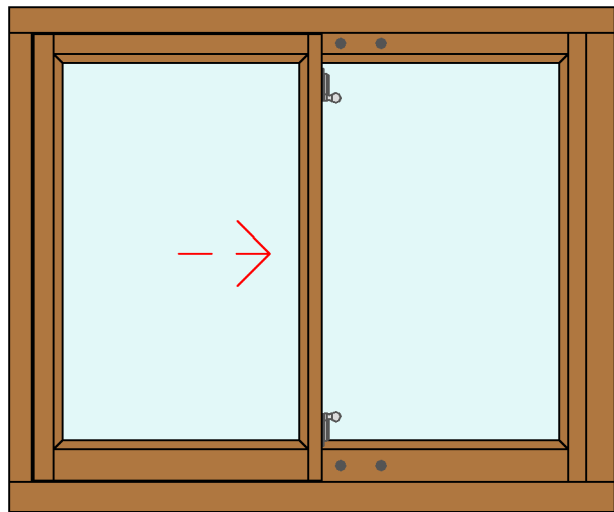

Section A-A - (Scale 1:2)

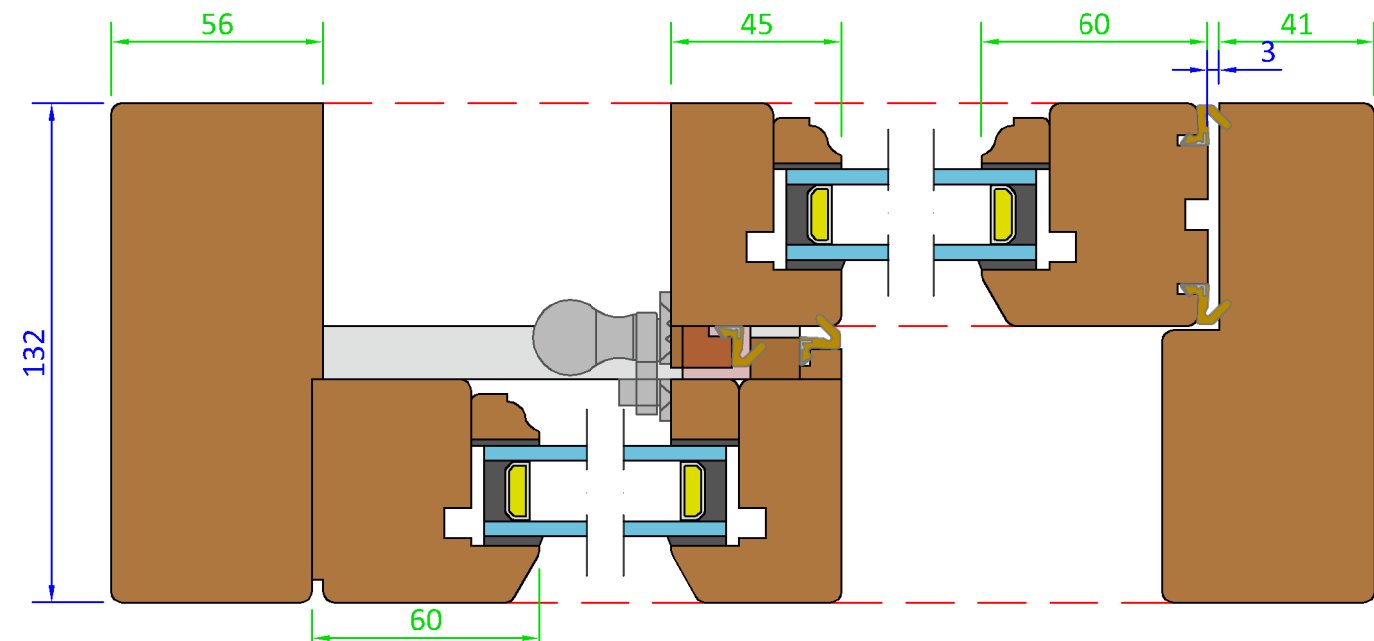

SECTIONS

Section B-B - (Scale 1:2)

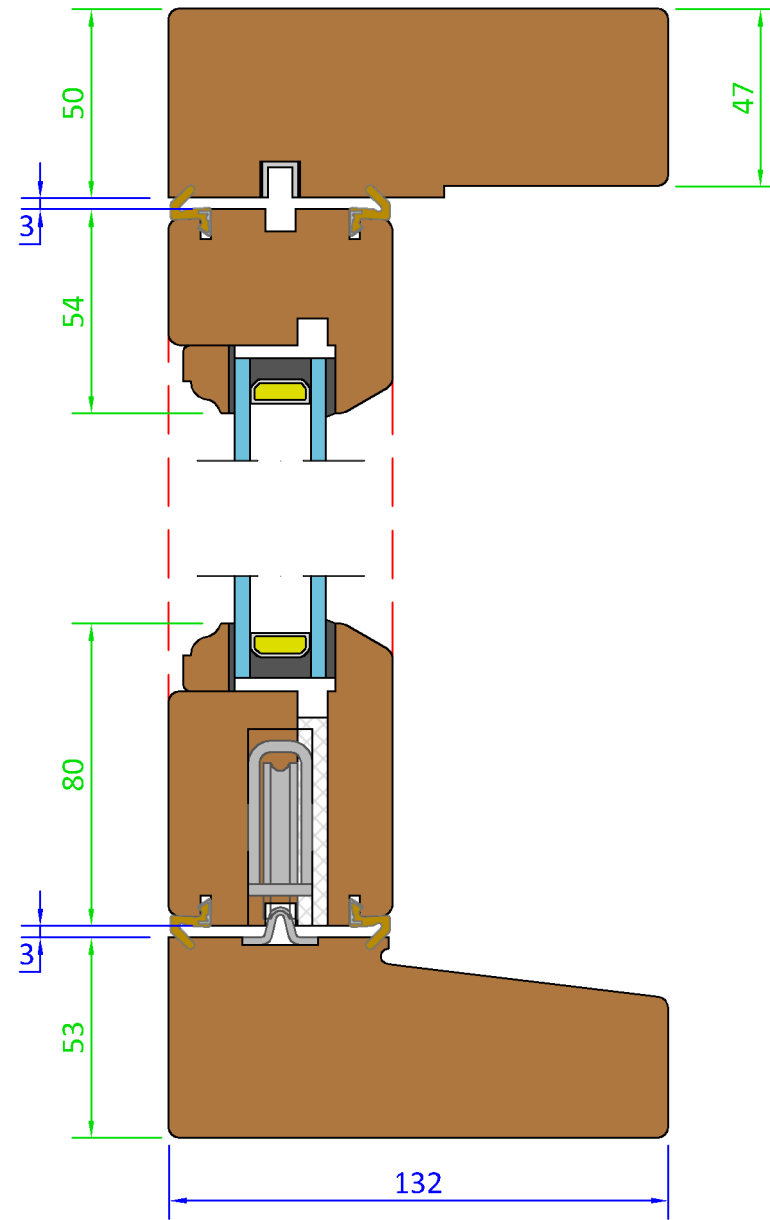

Section C-C - (Scale 1:2)

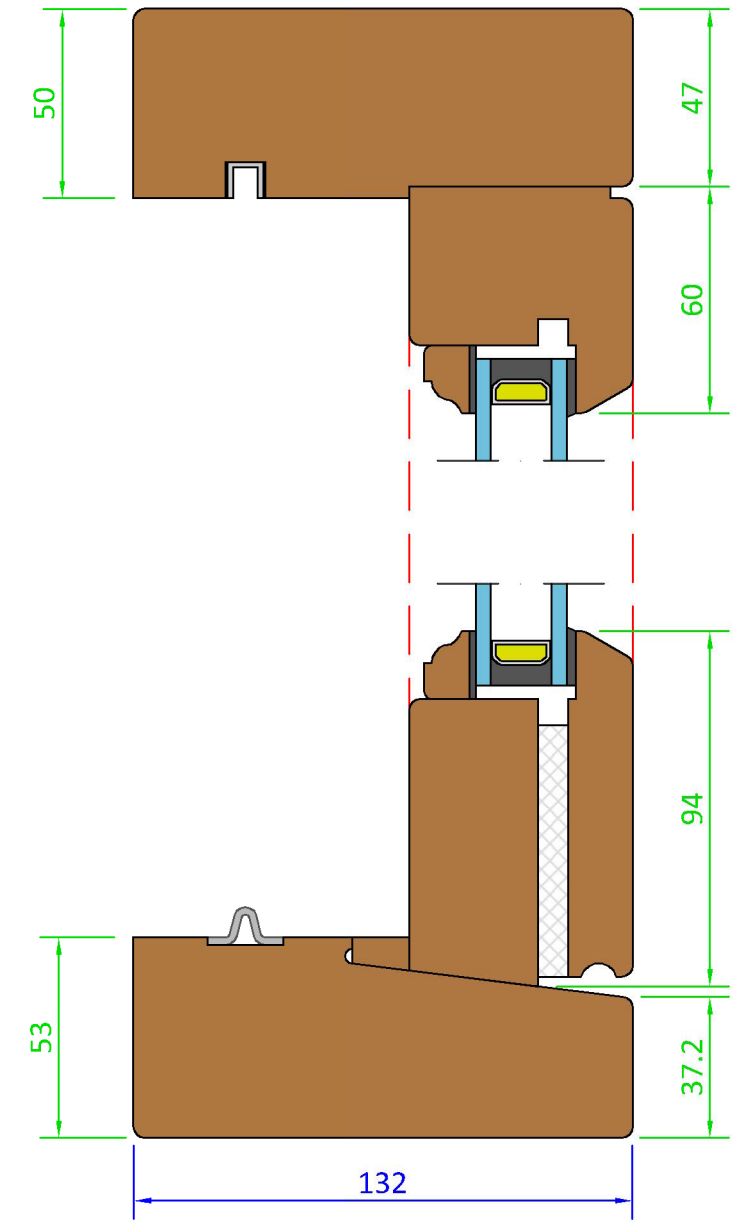

Drainage System

Variable Dimensions
(Dim shown is usually min)

Fixed Dimensions

System: T-H1-132		
Title: Traditional - Horizontal Sash Window (59mm)		
Scale:	Rev No:	Date:
As Shown	A	10-Oct-17
Drawn By:	Sheet No:	Status:
LH	1	Released

GEORGE BARNSDALE
Est. 1884
High Street, Donington, Spalding, Lincs, PE11 4TA
01775 823000
www.georgebarnsdale.co.uk

Perances: All tolerance are to George Barnsdale Standard Tolerance definitions (see suprtng document for more detail) unless stated on the drawing.
© George Barnsdale & Sons Ltd. All rights reserved. No part of this drawing may be reprinted without the permission of George Barnsdale & Son Ltd.

ELEVATIONS

Scheme 'G' Outside View (Scale 1:15)

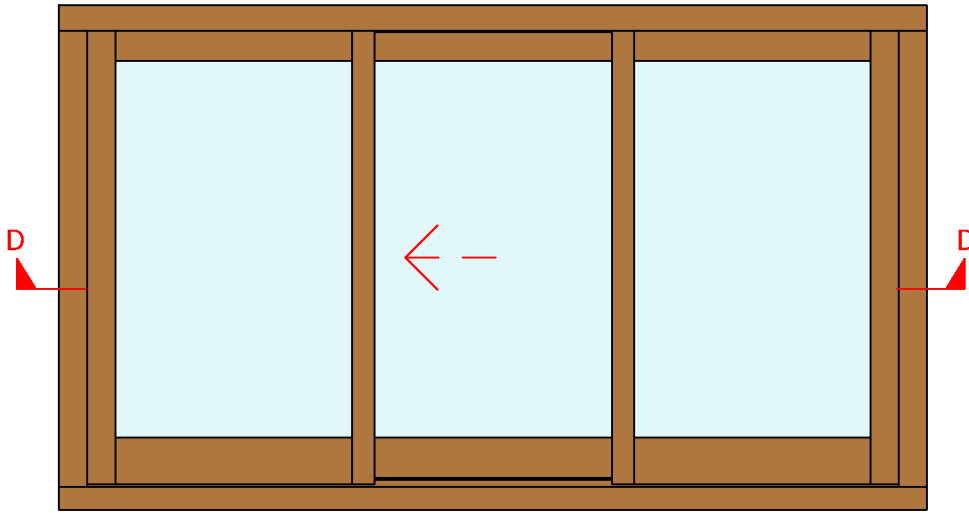

Scheme 'G' Inside View (Scale 1:15)

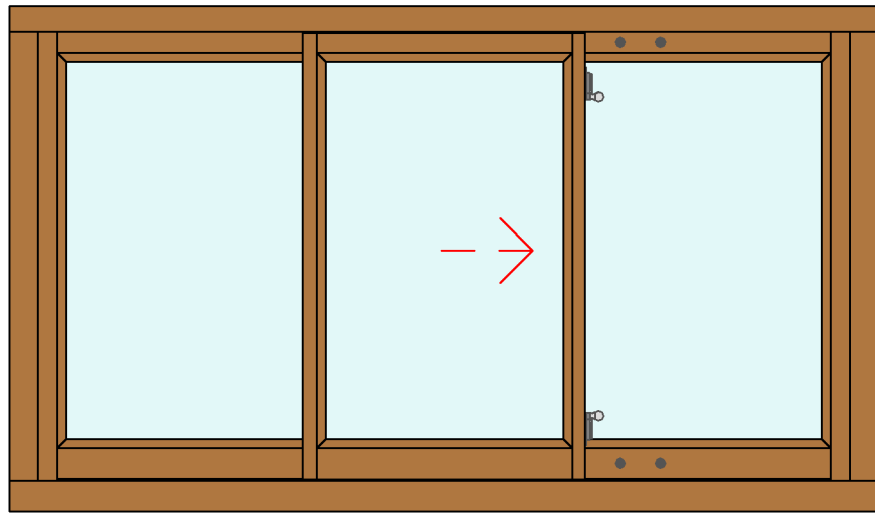

Fixed Sash Meeting Rail Strip detail - (Scale 1:2)

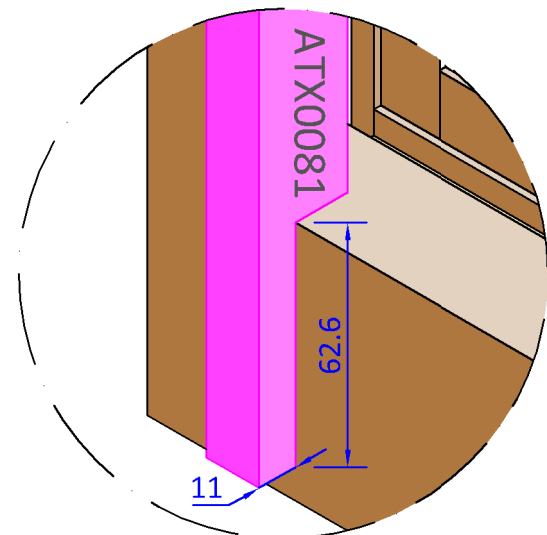

SECTIONS

Section D-D - (Scale 1:2)

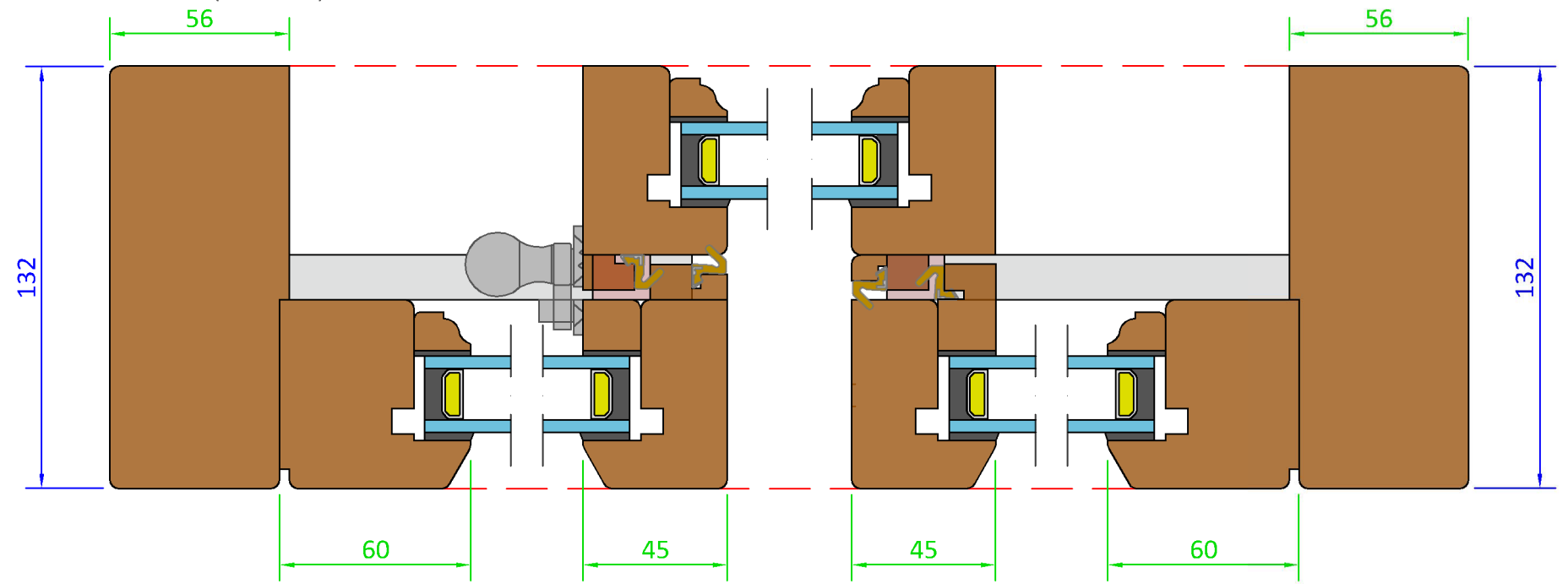

OPTIONS

Cill Extension Option - 30mm - (Scale 1:2)

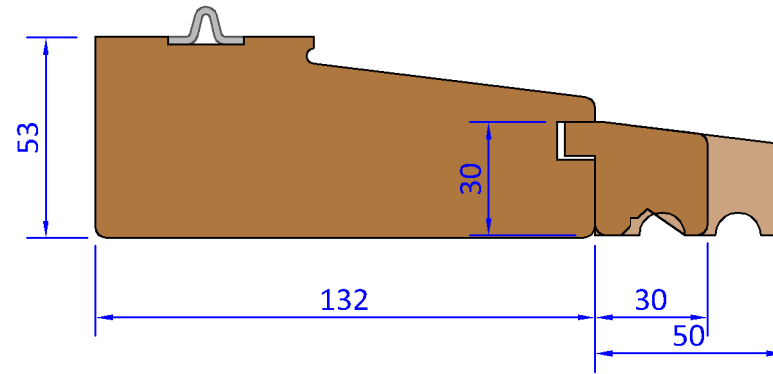

Cill Extension Option - 45mm - (Scale 1:2)

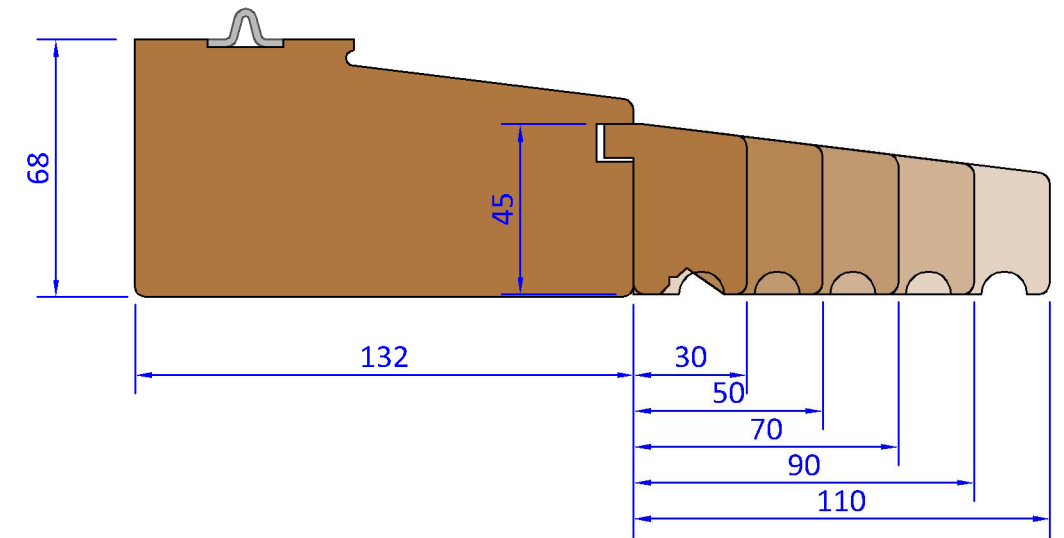

OPTIONS

Cill Extension Option - 35mm - (Scale 1:2)

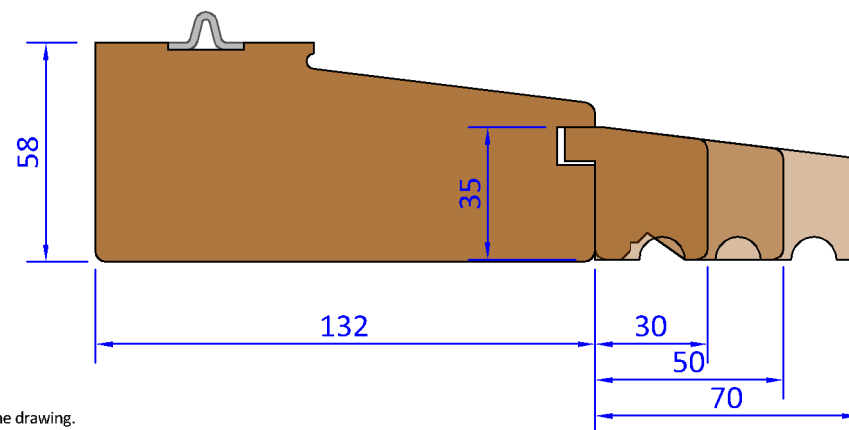

— Variable Dimensions
(Dim shown is usually min)
— Fixed Dimensions

System: T-H1-132			
Title: Traditional - Horizontal Sash Window (59mm)			
Scale:	As Shown	Rev No: A	Date: 10-Oct-17
Drawn By:	LH	Sheet No: 2	Status: Released

GEORGE BARNSDALE
Est. 1884
High Street, Donington, Spalding, Lincs, PE11 4TA
01775 823000
www.georgebarnsdale.co.uk

Tolerances: All tolerance are to George Barnsdale Standard Tolerance definitions (see supporting document for more detail) unless stated on the drawing.
© George Barnsdale & Sons Ltd. All rights reserved. No part of this drawing may be reproduced without the permission of George Barnsdale & Son Ltd.

DETAILS

Scheme 'A' Inside View (Scale 1:15)

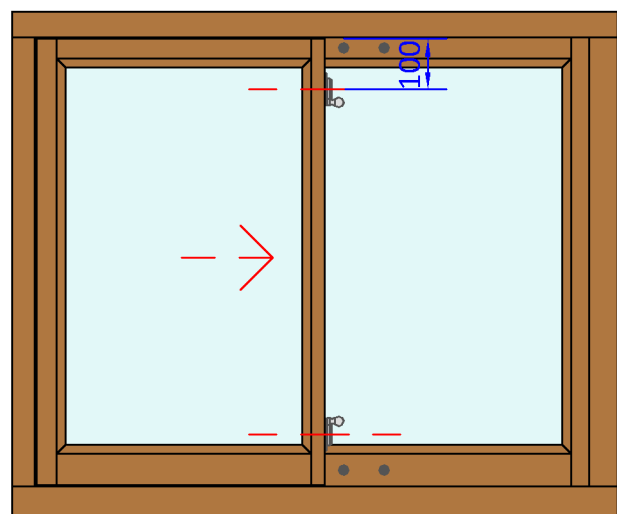

Sash Stop Option 'A' & 'K' - (Scale 1:5)

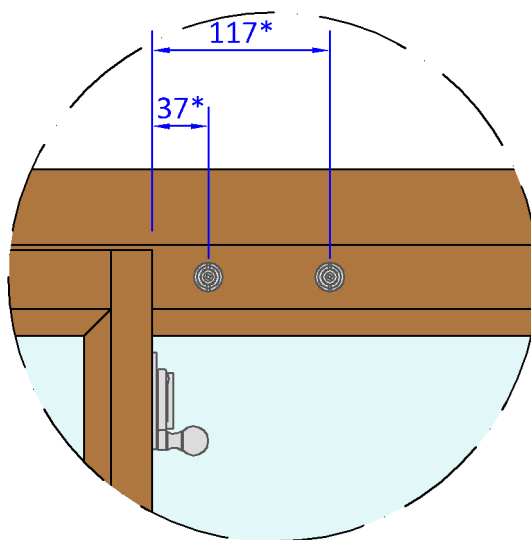

Vent Option - (Scale 1:2)

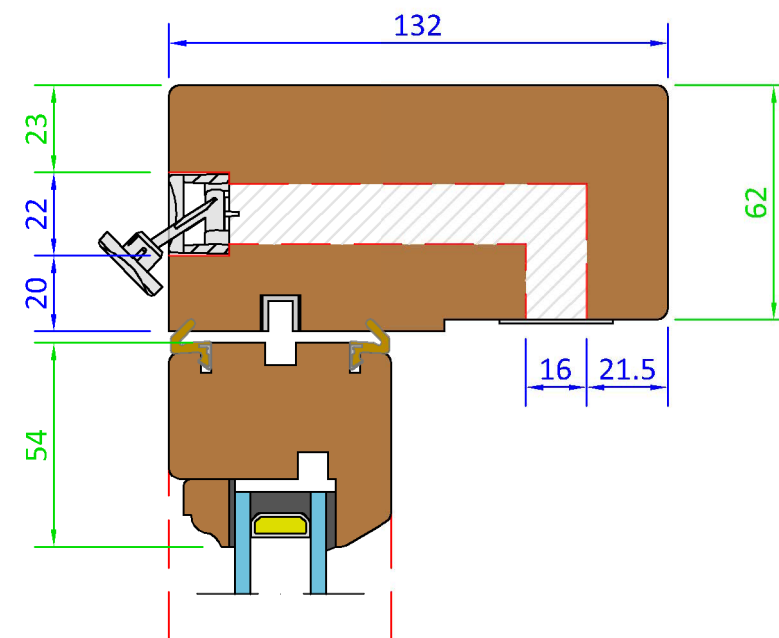

Scheme 'K' Outside View (Scale 1:15)

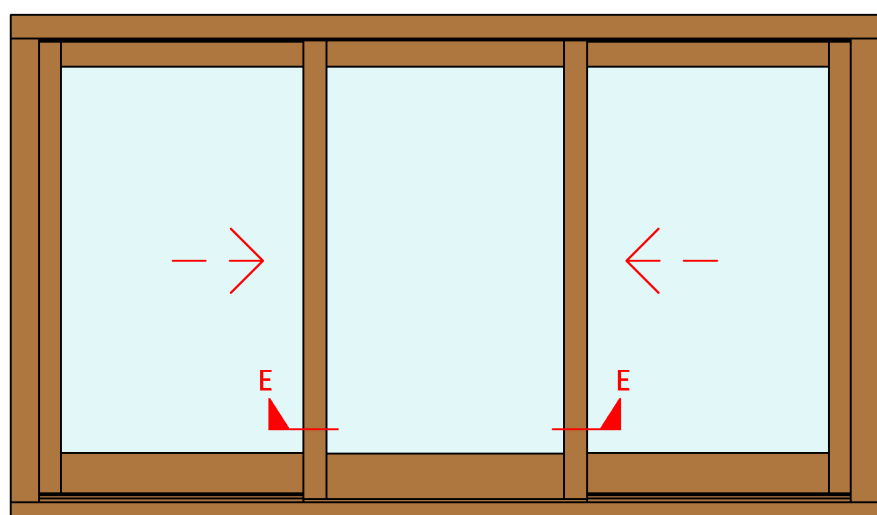

Sash Stop Option 'G' - (Scale 1:5)

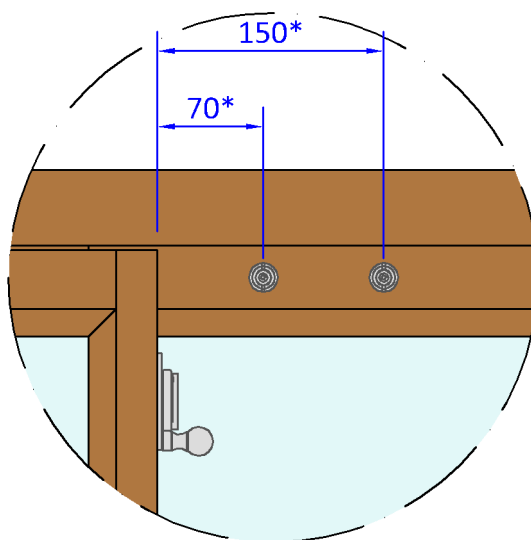

Fastener position as shown unless glazing bar requires alternative position which should then be positioned for best aesthetic by operator.

* Dimensions shown provide (100mm and 20mm respectively), ventilation openings at the side of the window

SECTIONS

Section E-E - (Scale 1:2)

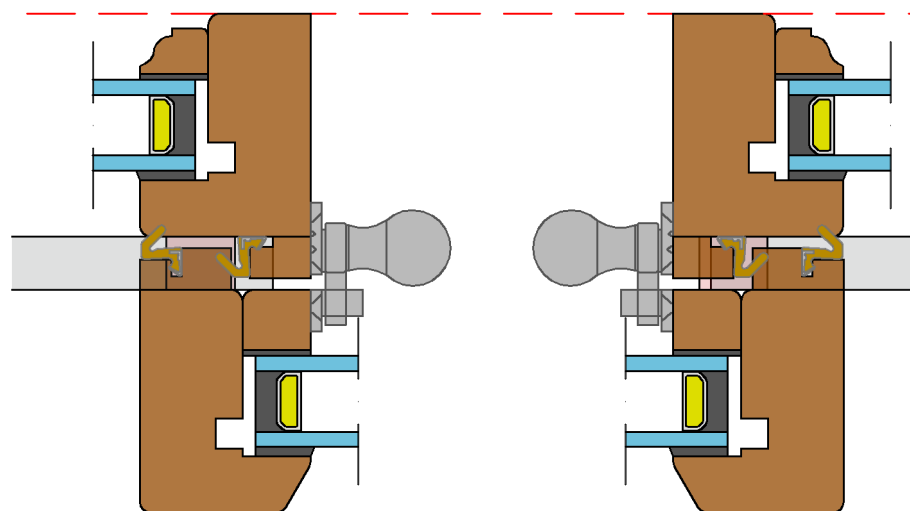

Drainage System

Vent System

Variable Dimensions (Dim shown is usually min)

Fixed Dimensions

System: T-H1-132		
Title: Traditional - Horizontal Sash Window (59mm)		
Scale: As Shown	Rev No: A	Date: 10-Oct-17
Drawn By: LH	Sheet No: 3	Status: Released

GEORGE BARNSDALE
 Est. 1884
 High Street, Donington, Spalding, Lincs, PE11 4TA
 01775 823000
 www.georgebarnsdale.co.uk