

ELEVATIONS

Elevation 1 - Outside View (Scale 1:10)

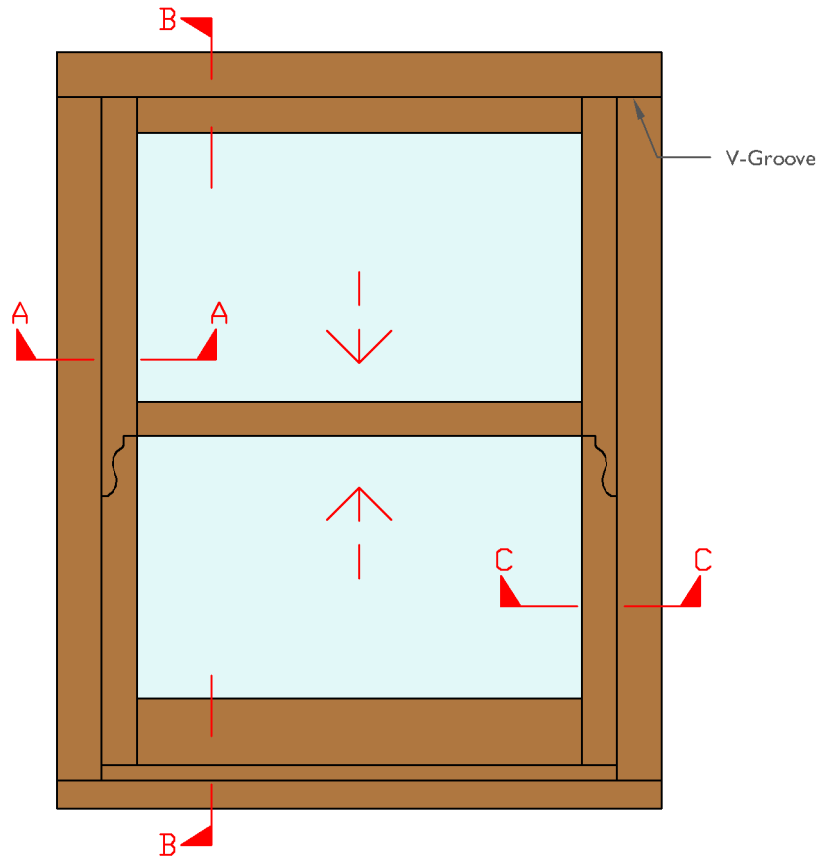

Elevation 2 - Inside View (Scale 1:10)

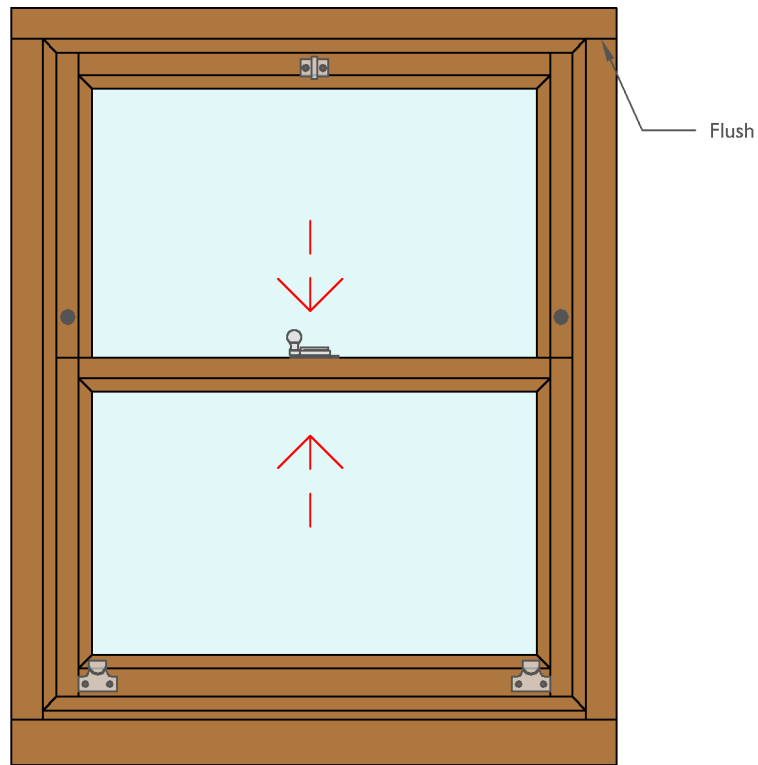

SECTIONS

Section A-A - Upper Jamb (Scale 1:2)

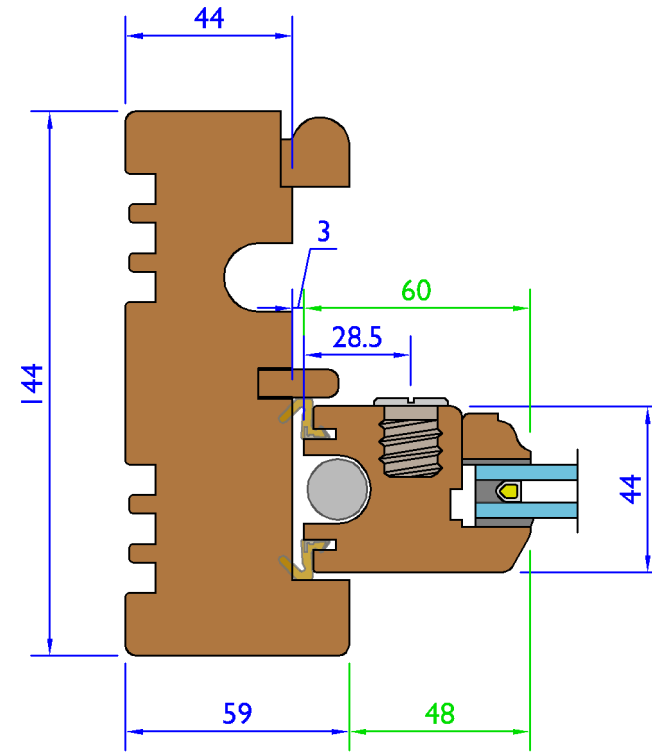

Section C-C - Lower Jamb (Scale 1:2)

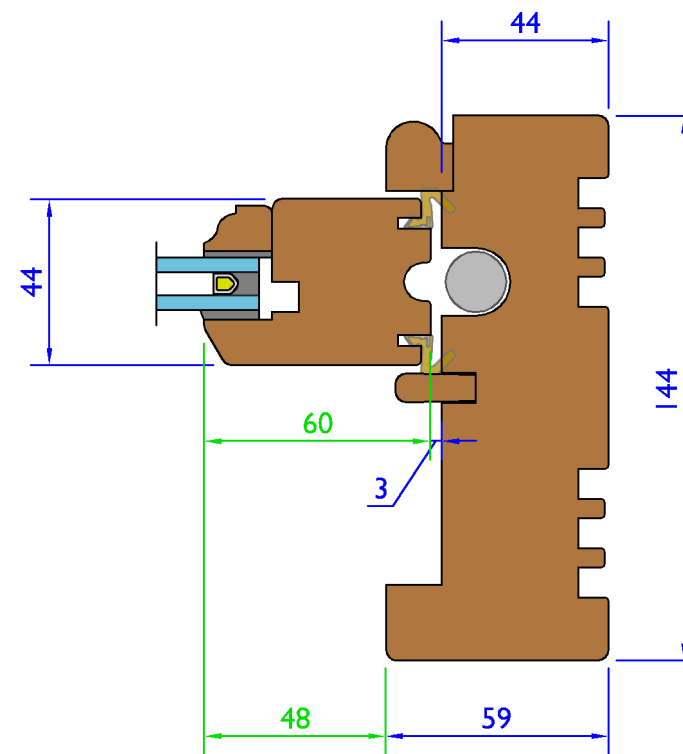

Section B-B - Head, Cill and Meeting Rails - (Scale 1:2)

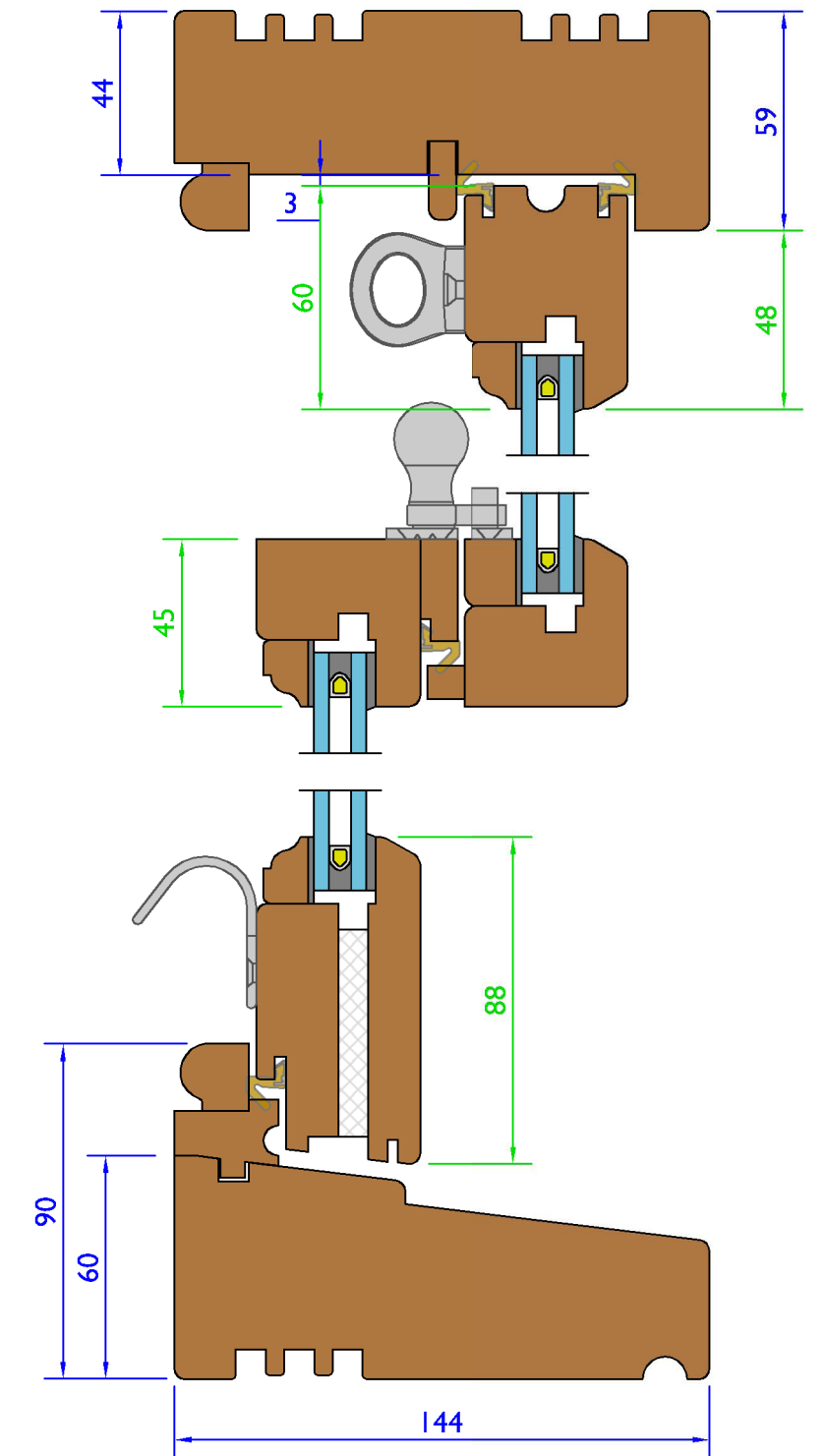

Drainage System

Variable Dimensions
(Dim shown is usually min)

Fixed Dimensions

Tolerances: All tolerances are to George Barnsdale Standard Tolerance definitions (see supporting document for more detail) unless stated on the drawing.
© George Barnsdale & Sons Ltd. All rights reserved. No part of this drawing may be reproduced without the permission of George Barnsdale & Son Ltd.

System: T-S2-144		
Title: Traditional Slim - Spring Balance Sash Window (44mm)		
Scale:	As Shown	Rev No: A
		Date: 20-Apr-18
Drawn By:	LH	Sheet No: 1
		Status: Released

GEORGE BARNSDALE
Est. 1884
High Street, Donington, Spalding, Lincs, PE11 4TA
01775 823000
www.georgebarnsdale.co.uk

SASH AND FRAME OPTIONS

Cill Extension Option - 45mm - (Scale 1:2)

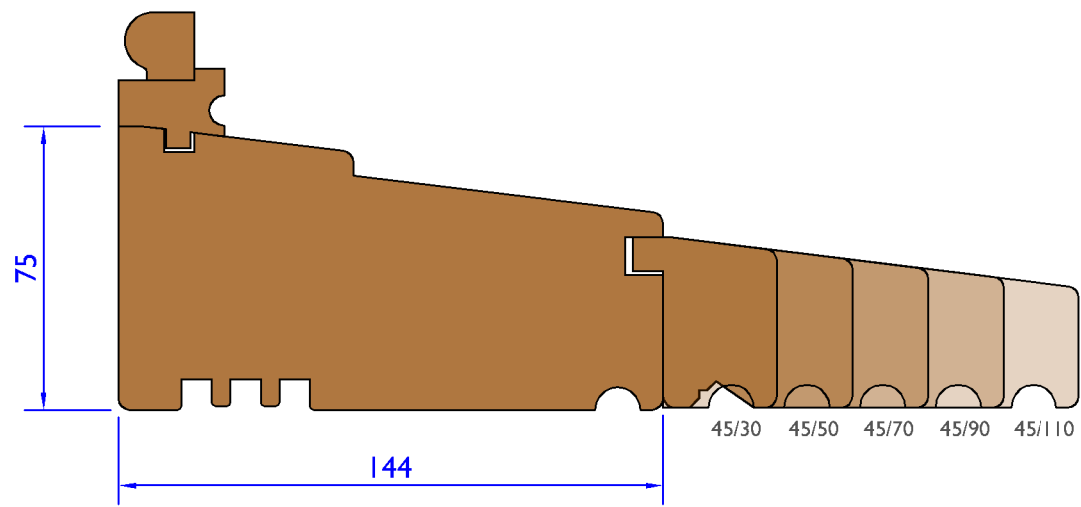

Cill Extension Option - 35mm - (Scale 1:2)

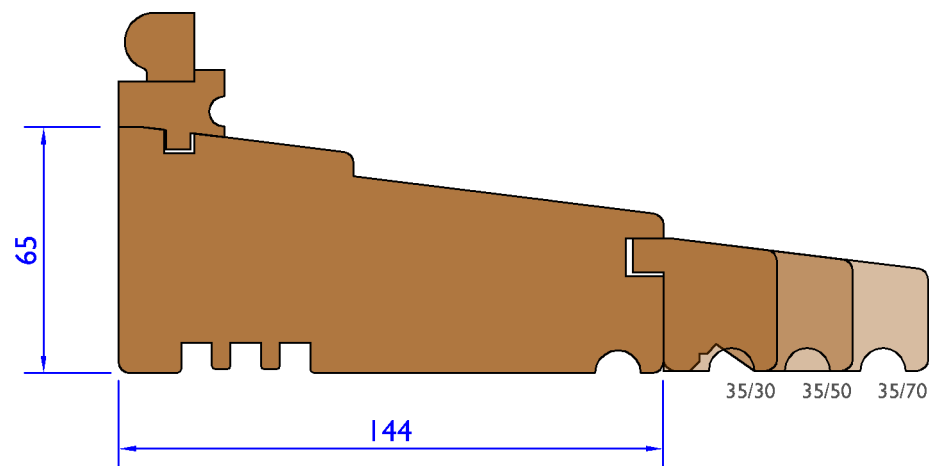

Cill Extension Option - 30mm - (Scale 1:2)

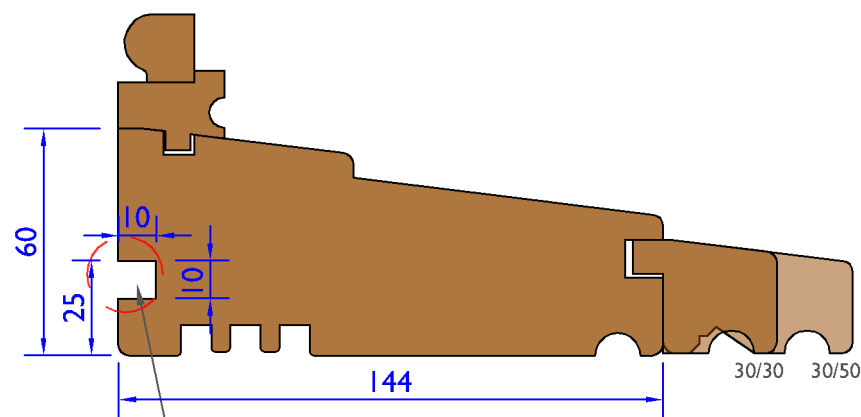

Optional windowboard groove

Transome Detail - Section D-D - (Scale 1:2)

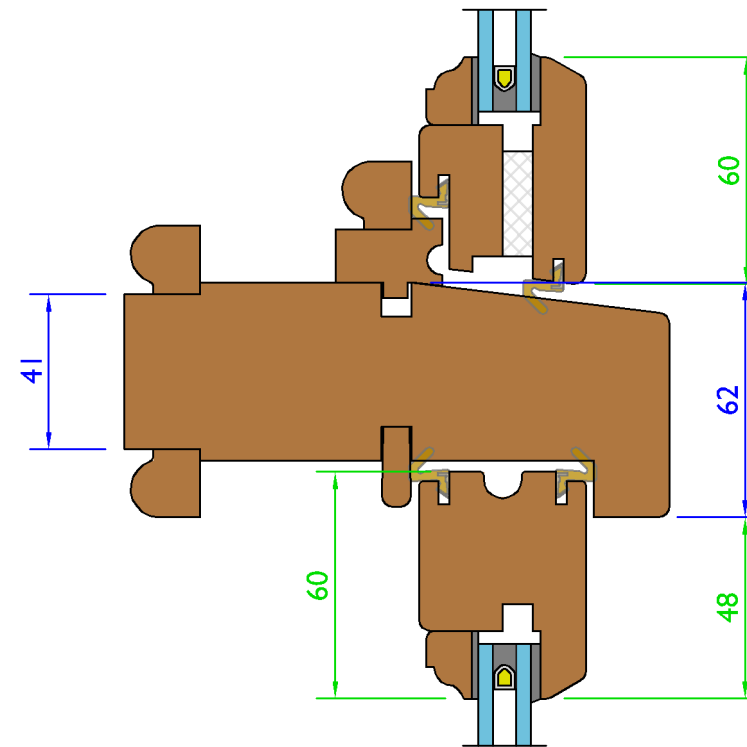

Solid Mullion Detail - Section E-E - (Scale 1:2)

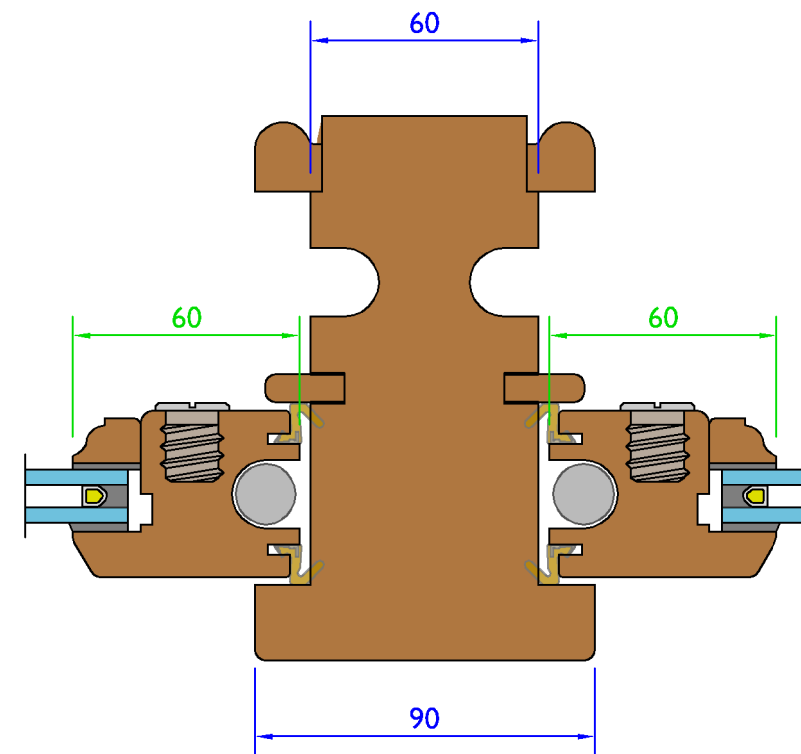

Arch Elevation - (Scale 1:20)

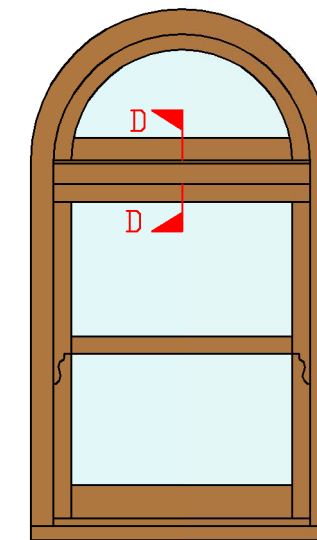

Double window Elevation - (Scale 1:20)

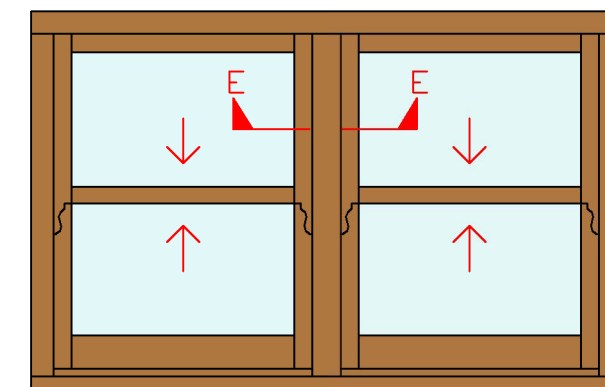

Drainage System

Variable Dimensions
(Dim shown is usually min)

Fixed Dimensions

Tolerances: All tolerances are to George Barnsdale Standard Tolerance definitions (see supporting document for more detail) unless stated on the drawing.
© George Barnsdale & Sons Ltd. All rights reserved. No part of this drawing may be reproduced without the permission of George Barnsdale & Son Ltd.

System: T-S2-144		
Title: Traditional Slim - Spring Balance Sash Window (44mm)		
Scale: As Shown	Rev No: A	Date: 20-Apr-18
Drawn By: LH	Sheet No: 2	Status: Released

GEORGE BARNSDALE
Est. 1884
High Street, Donington, Spalding, Lincs, PE11 4TA
01775 823000
www.georgebarnsdale.co.uk

Frame Vent Elevation Detail Showing Hidden Slot Size - (Scale 1:10)

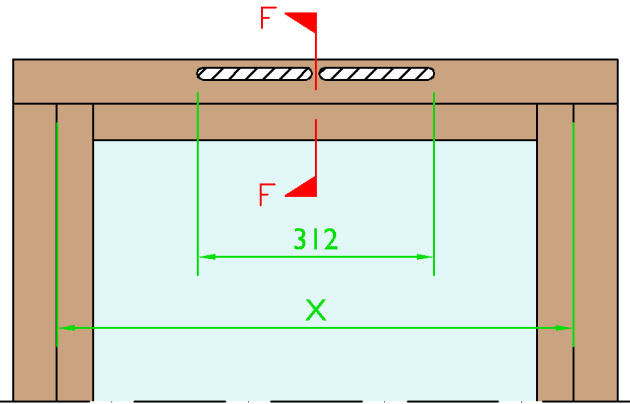

Vent not possible if X is under 400mm

Shallow Arch Elevation Detail - (Scale 1:10)

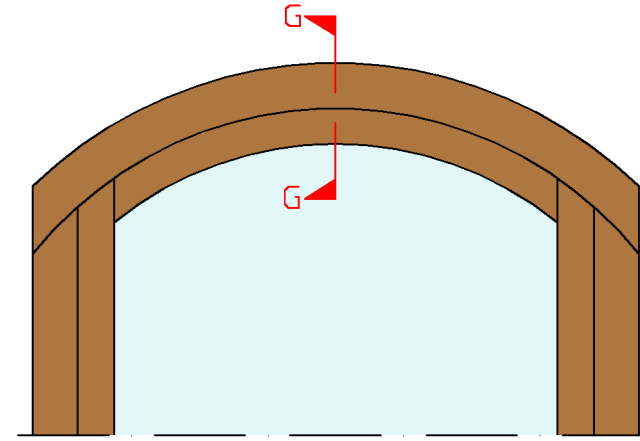

Head Vent Detail Section F-F - (Scale 1:2)

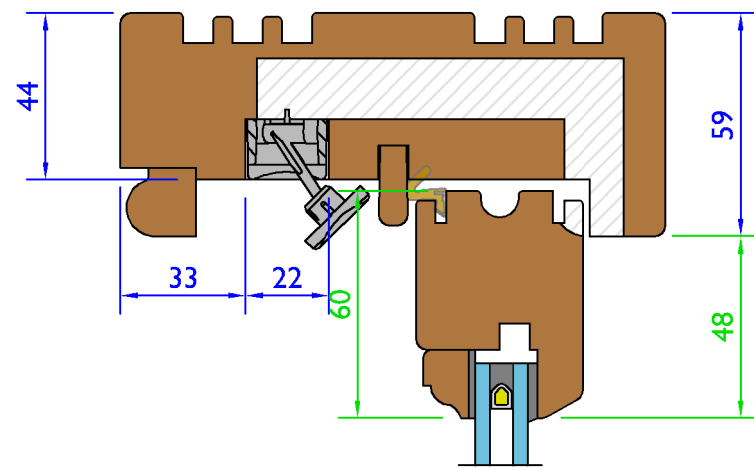

Semi-circular Arch Elevation Detail - (Scale 1:10)

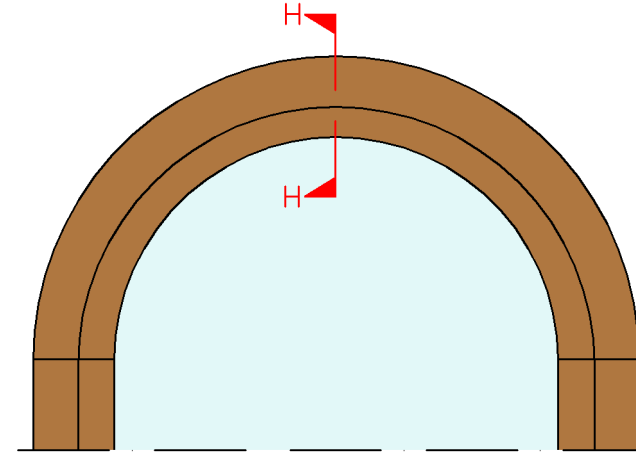

MEETING RAIL PLUGS DETAILS

Bottom sash meeting rail brush seal - (Scale 1:2)

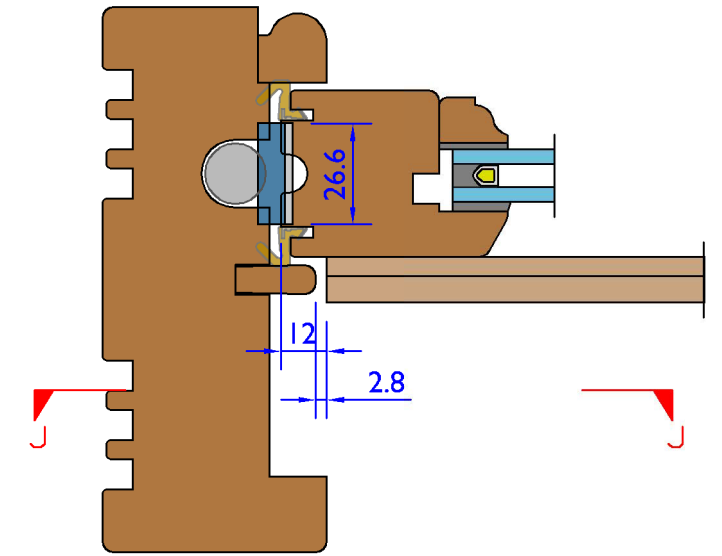

Extended Lining Option - (Scale 1:2)

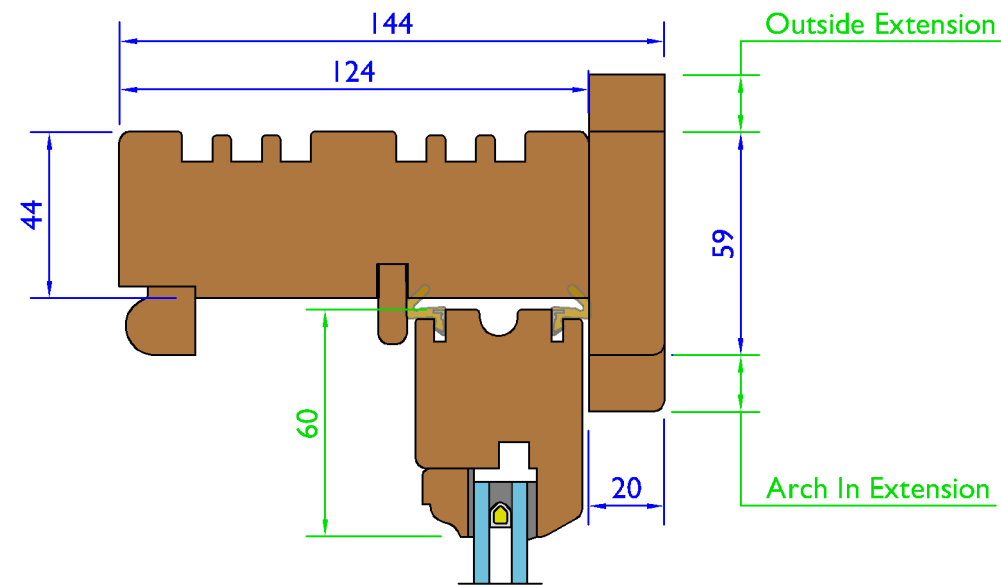

ARCHED HEAD

Arch Detail Section G-G and H-H - (Scale 1:2)

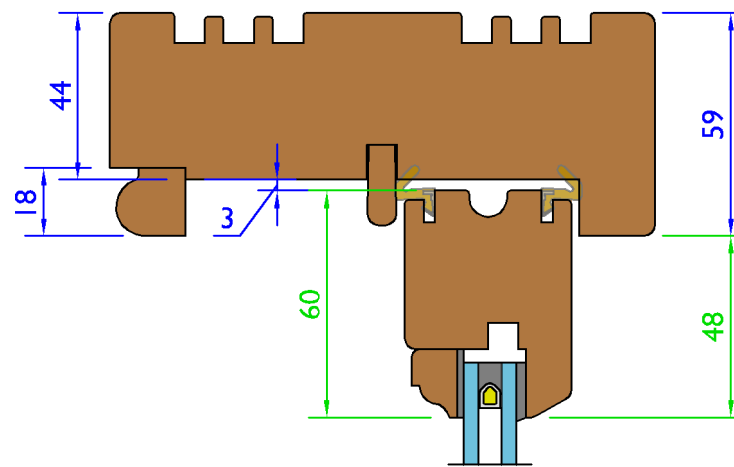

Elevation view of section J-J, parting bead seal - (Scale 1:2)

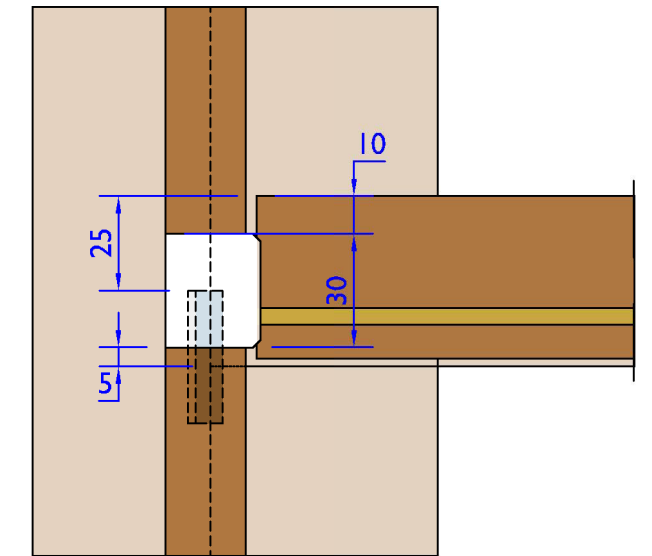

Vent System

Variable Dimensions
(Dim shown is usually min)

Fixed Dimensions

Tolerances: All tolerances are to George Barnsdale Standard Tolerance definitions (see supporting document for more detail) unless stated on the drawing.
© George Barnsdale & Sons Ltd. All rights reserved. No part of this drawing may be reproduced without the permission of George Barnsdale & Son Ltd.

System: T-S2-144		
Title: Traditional Slim - Spring Balance Sash Window (44mm)		
Scale:	Rev No:	Date:
As Shown	A	20-Apr-18
Drawn By:	Sheet No:	Status:
LH	3	Released

GEORGE BARNSDALE
Est. 1884
High Street, Donington, Spalding, Lincs, PE11 4TA
01775 823000
www.georgebarnsdale.co.uk

SASH HORN OPTIONS (Scale 1:2)

Sash Horn Type A

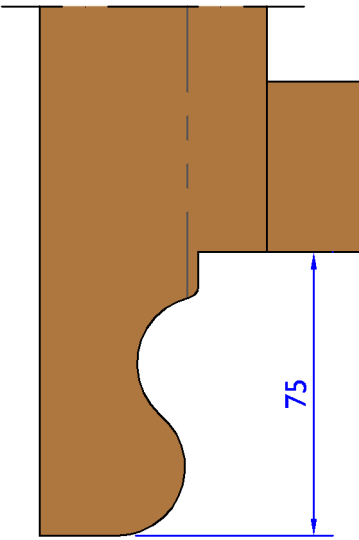

Sash Horn Type B

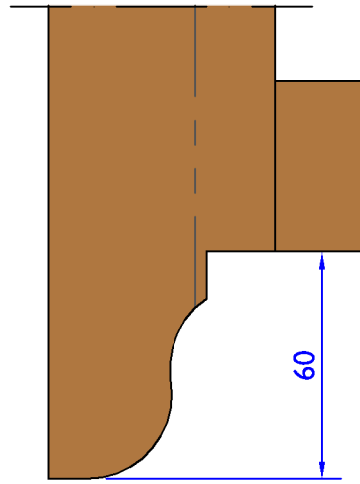

Sash Horn Type C

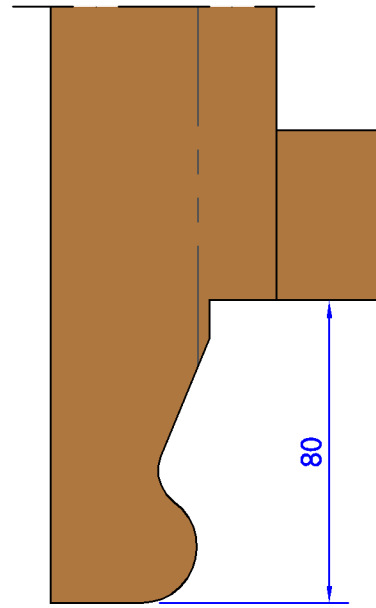

Sash Horn Type D

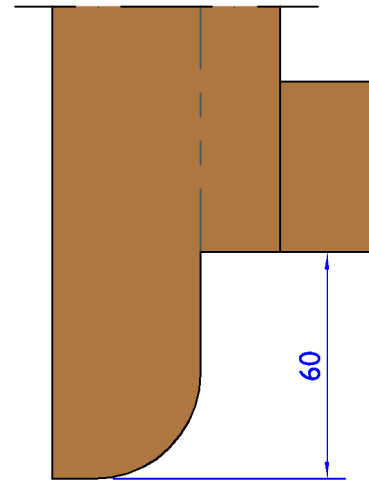

Sash Horn Type E

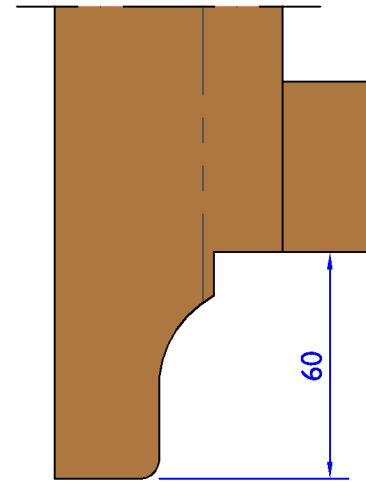

Sash Horn Type F

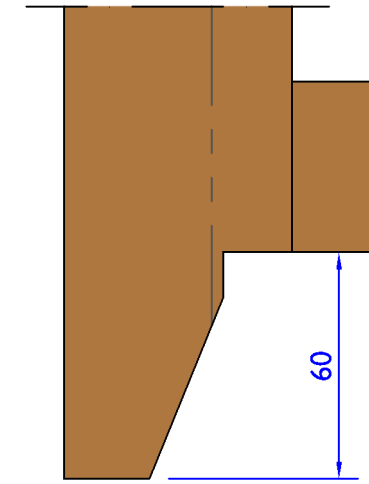

Sash Horn Type G

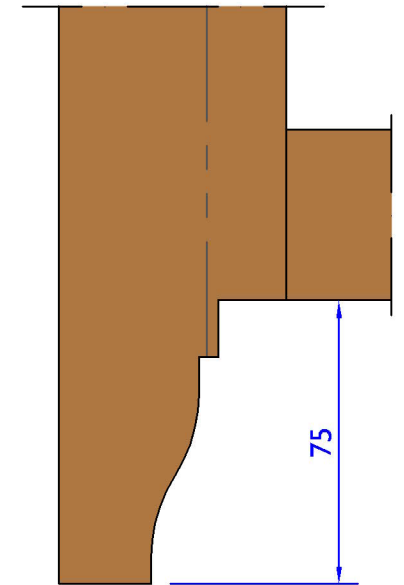

Sash Pull Position (sash width <900 mm) - (Scale 1:10)

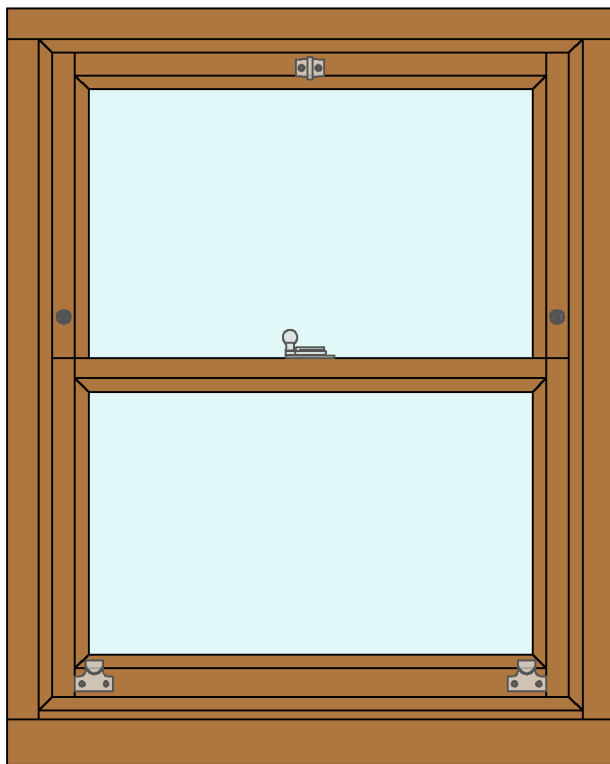

Sash pull aligned with sash rebate. Sash fastener centralised unless glazing bar requires it to be offset (offset to RHS when viewed from inside unless specified otherwise)

Sash Pull + Fastener Position (sash width >900 mm) - (Scale 1:10)

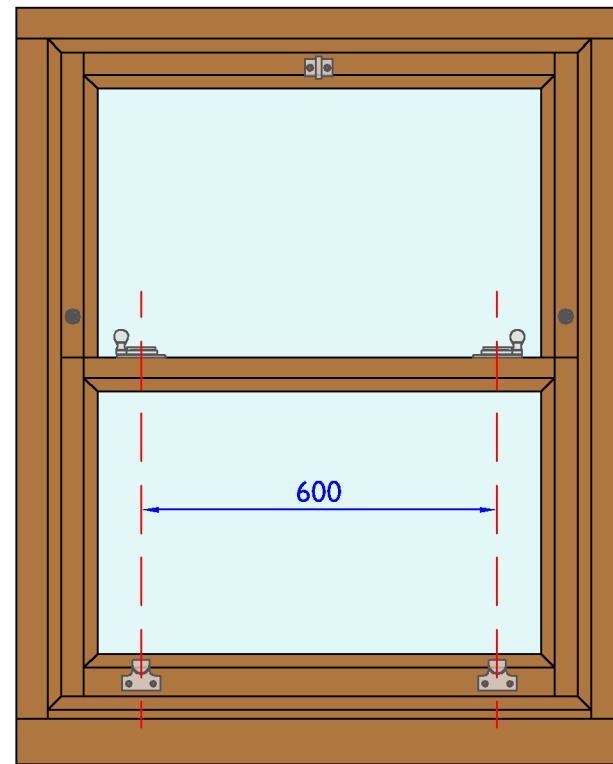

Sash pull aligned with sash fastener. Pull and fastener position as shown unless glazing bar requires alternative position which should then be positioned for best aesthetic by operator.

Double Sash Stop Option - (Scale 1:5)

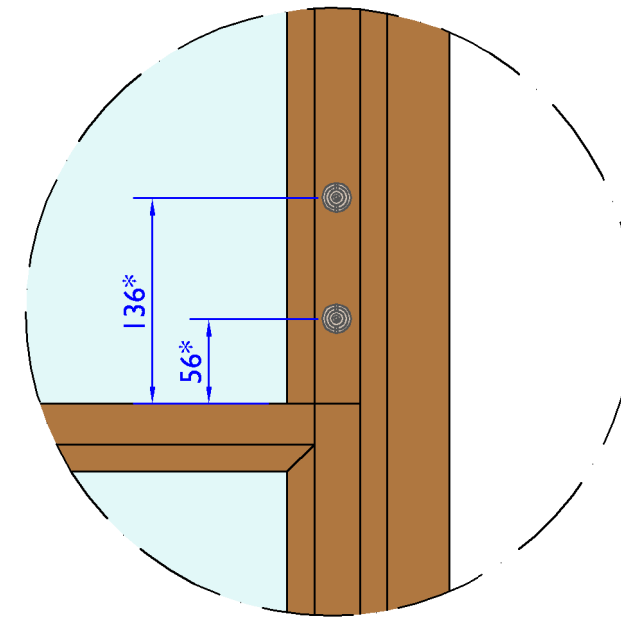

* Dimensions shown provide (100mm and 20mm respectively), ventilation openings at the bottom of the window

— Variable Dimensions (Dim shown is usually min)
— Fixed Dimensions

System: T-S2-144		
Title: Traditional Slim - Spring Balance Sash Window (44mm)		
Scale: As Shown	Rev No: A	Date: 20-Apr-18
Drawn By: LH	Sheet No: 4	Status: Released

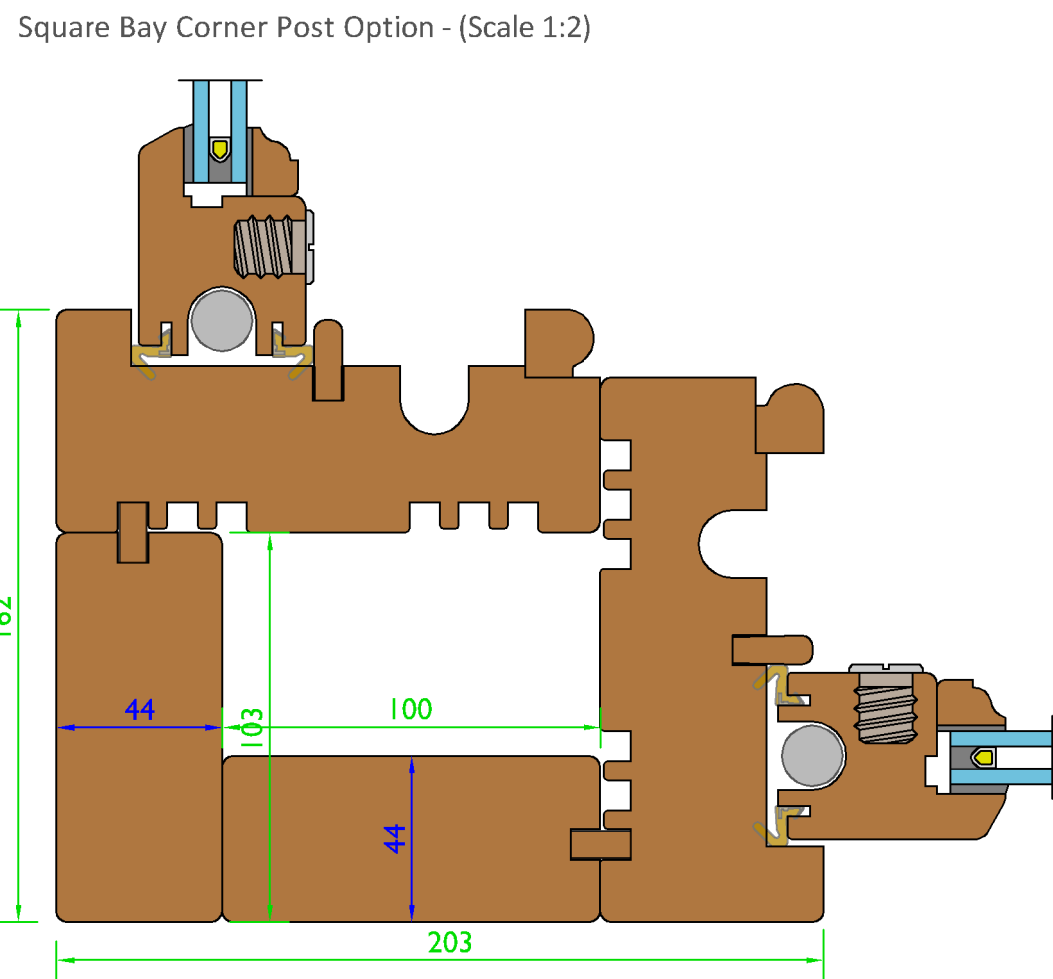
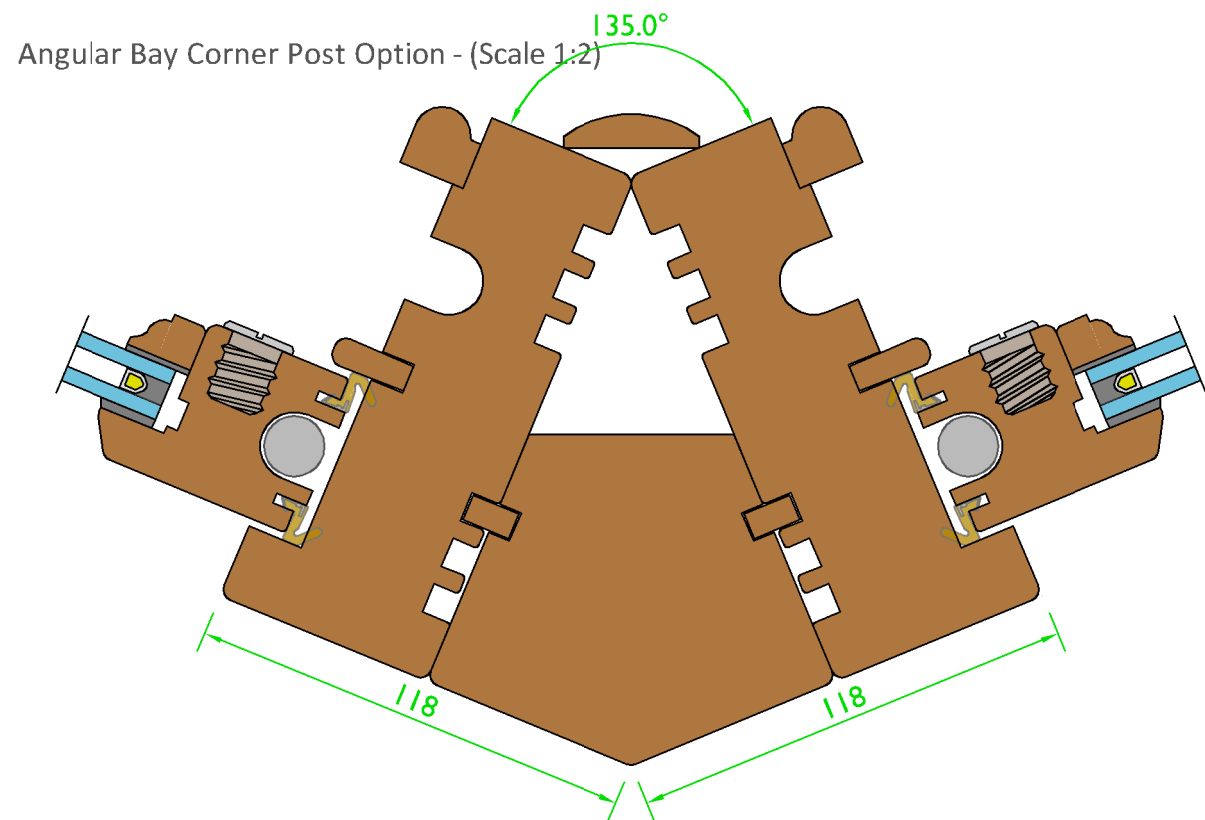

Frame Outside Profile Options - (Scale 1:2)

Ovolo Profile Option

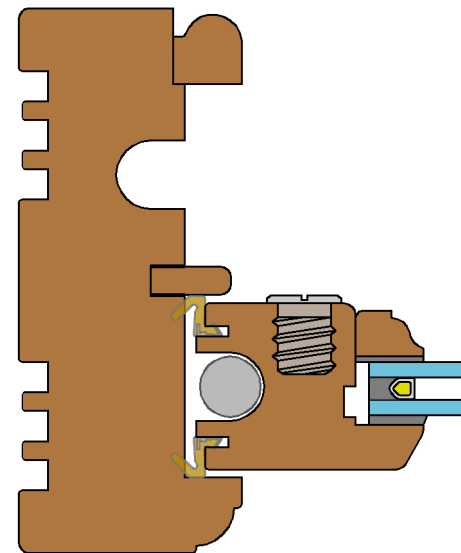

Bead Profile Option

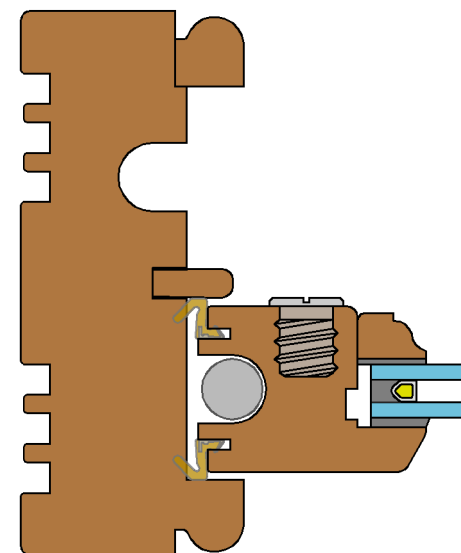

Frame Inside & Sash Outside Profile Options - (Scale 1:2)

Frame Inside Type F

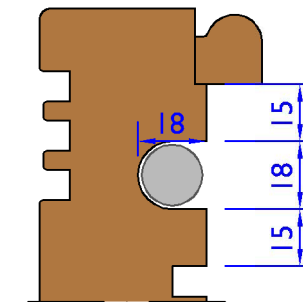

Frame Inside Type K

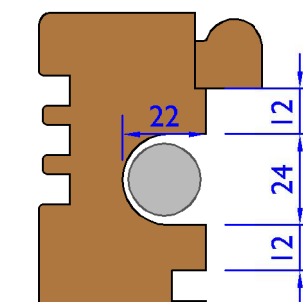

Side Rail Type F

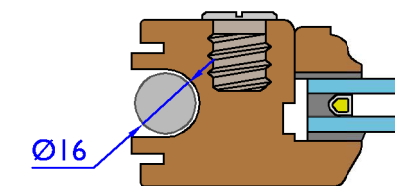

Side Rail Type K

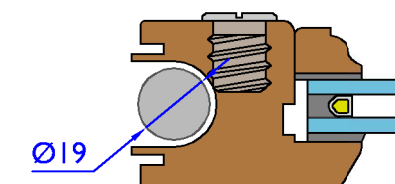

Variable Dimensions
(Dim shown is usually min)

Fixed Dimensions

System: T-S2-144		
Title: Traditional Slim - Spring Balance Sash Window (44mm)		
Scale:	Rev No:	Date:
As Shown	A	20-Apr-18
Drawn By:	Sheet No:	Status:
LH	5	Released

GEORGE BARNSDALE
Est. 1884
High Street, Donington, Spalding, Lincs, PE11 4TA
01775 823000
www.georgebarnsdale.co.uk

Tolerances: All tolerances are to George Barnsdale Standard Tolerance definitions (see supporting document for more detail) unless stated on the drawing.
© George Barnsdale & Sons Ltd. All rights reserved. No part of this drawing may be reproduced without the permission of George Barnsdale & Son Ltd.